

Plan View

10'

10'

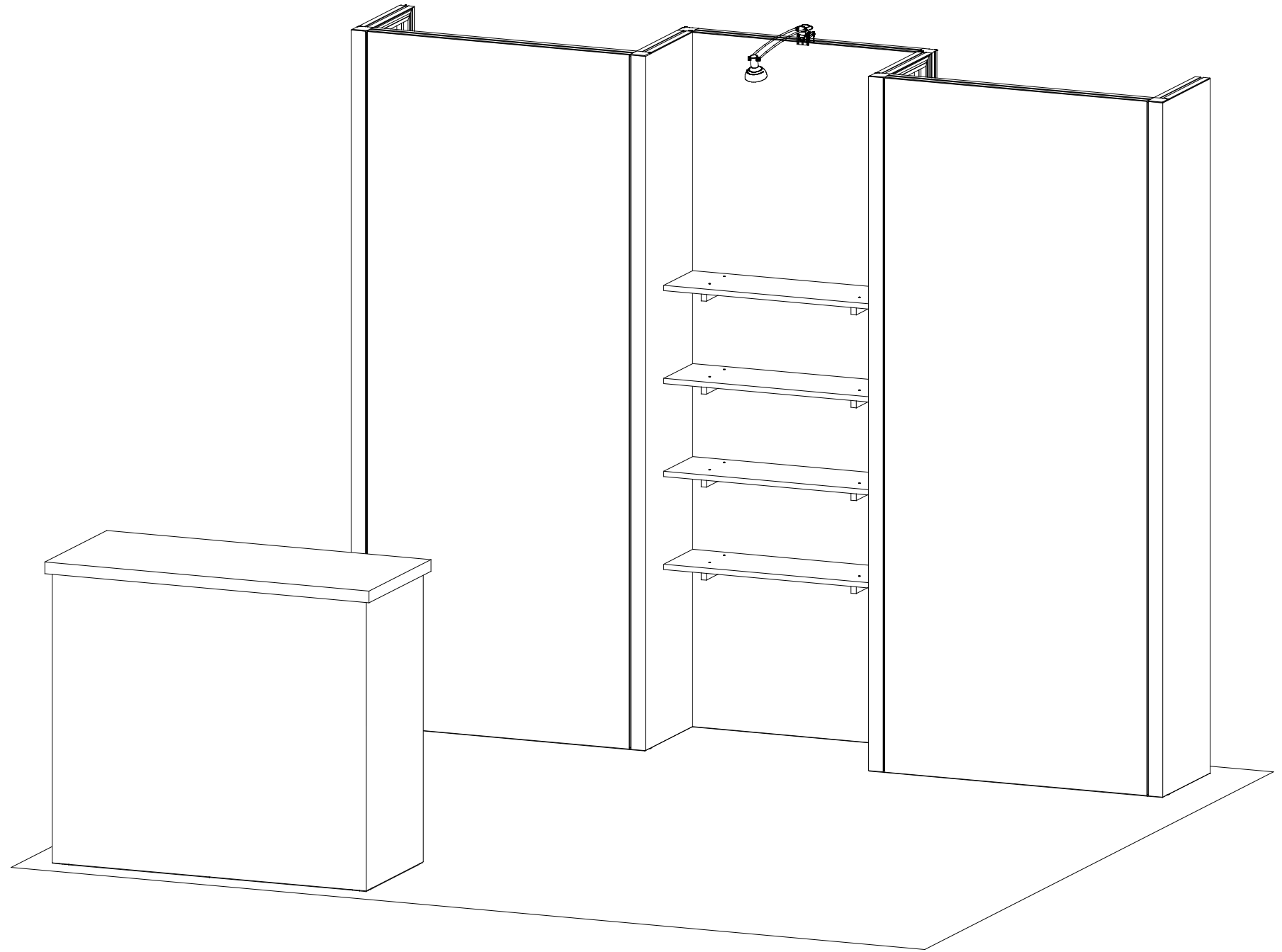

# ***SETUP INSTRUCTIONS***

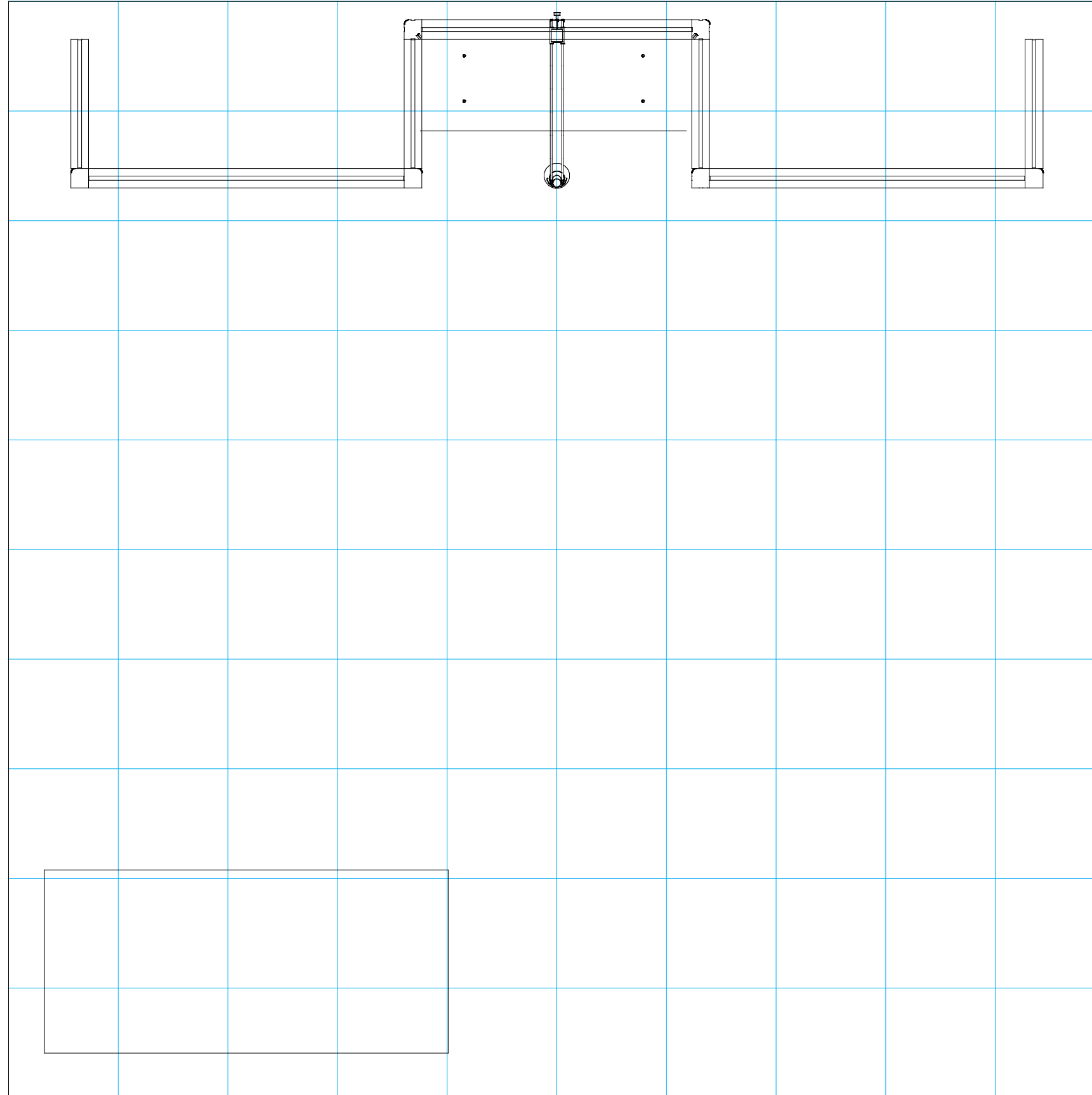

= 1 sq foot

## General Setup Instructions

- Read entire setup instruction manual prior to unpacking parts and pieces.
- The setup instructions are created specifically for this configuration.
- Setup instructions are laid out sequentially in steps, including exploded views with detailed explanation for assembly.

## Cleaning & Packing

- For Cleaning Metal, Plex, & Laminate Parts: Use a **MILD NON-ABRASIVE** cleanser and soft cloth/paper towel to clean all surfaces.
- Keep exhibit components away from heat and prolonged sun exposure. **Heat and UV exposure will warp and fade components.**
- Retain all provided Packing Materials. All provided packing materials are for ease of repacking & component protection.

## Disassembly

- For loss prevention, tighten all set screws and locks during disassembly.

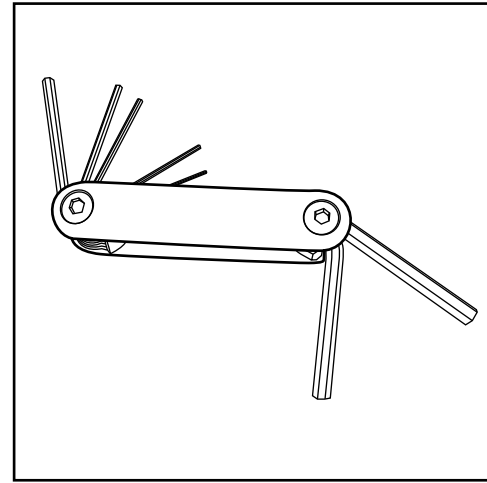

Hex Tool - Essential for Assembly

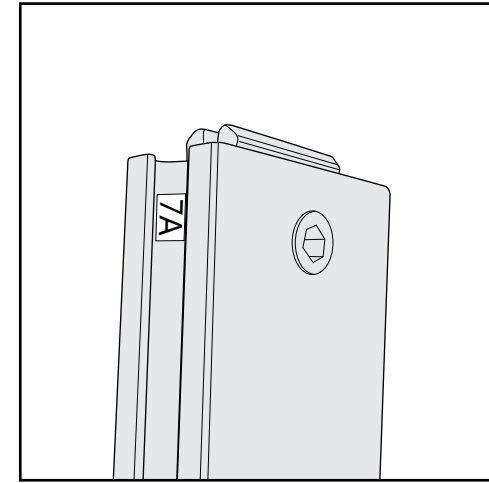

Part Identification - Numbering

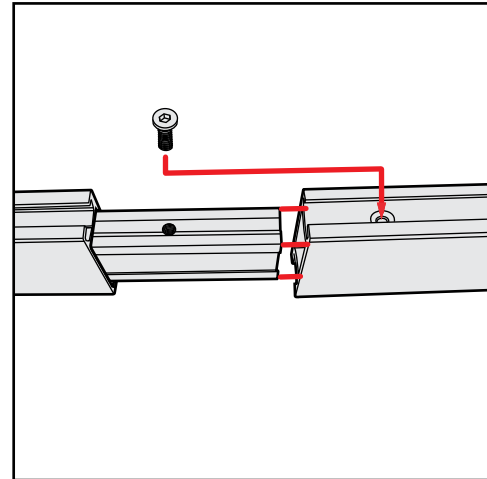

Spline Connection

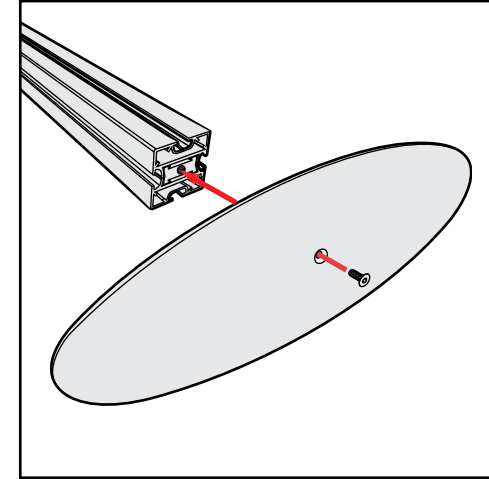

Base Plate & Extrusion Connection

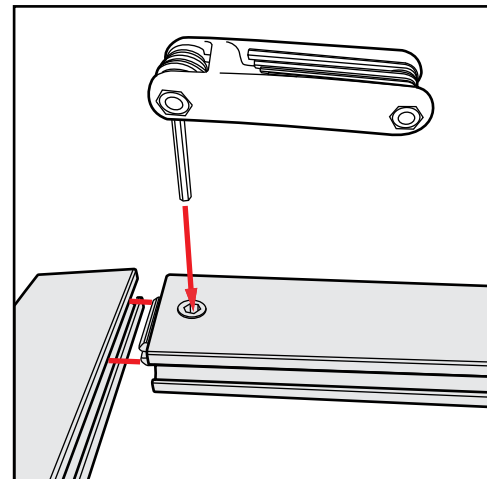

Extrusion & Lock Connection

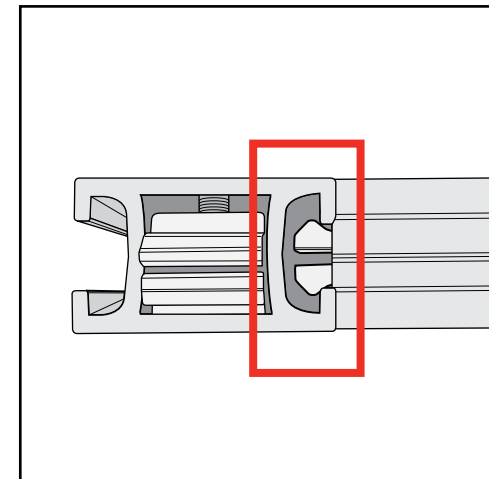

Engaged Lock



# WARNING



DO NOT USE POWER TOOLS



LADDERS OR LIFTS  
MAY BE REQUIRED



ALL CONNECTIONS MUST  
BE TIGHTLY SECURED

## Side-by-Side Assembly

- 1) Frames: Place frames side-by-side with one higher than the other, then slide panel down to lock panels securely together.
- 2) Corner Connectors: Repeat Step 1 for installing corner connectors to frames.

## Side-by-Side Disassembly

- 1) Pull pin lock outwards to disengage.
- 2) Pull frames upward and apart at the same time to detach.

Assembly

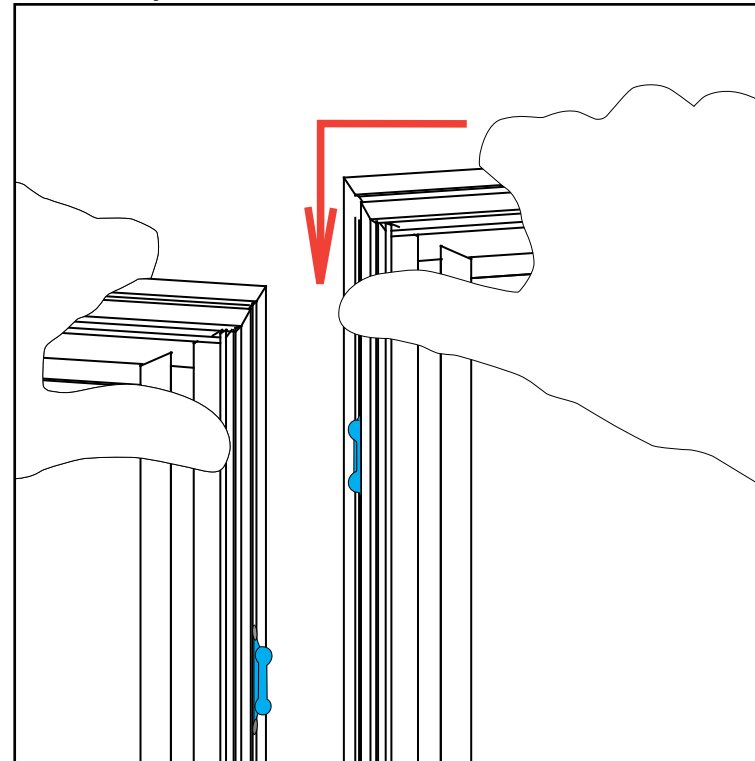

Assembly Cont'd

Push pin lock into hole of connecting frame.  
Note: Block of pin lock will secure in groove.

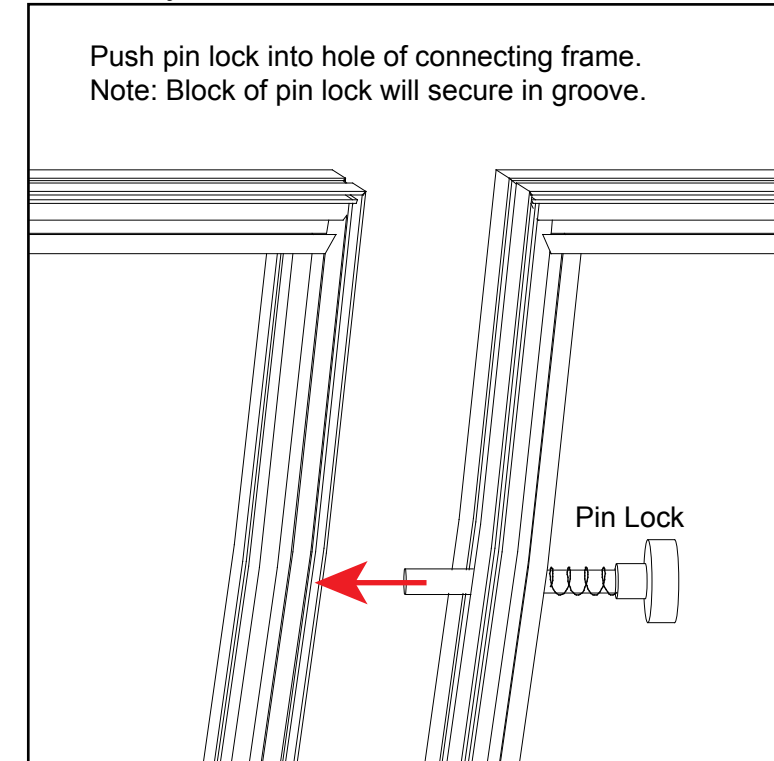

Corner Connector

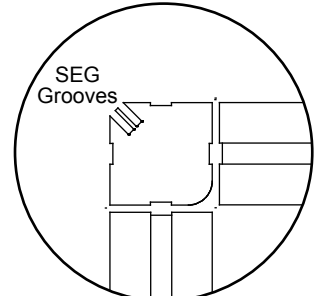

Top View  
Note: Orientation of Corner Connector may change.

## Stacking Assembly

- 1) Place one horizontal frame on top of the other, lining up the center grooves.
- 2) Turn stacking lock clockwise to tighten into place. Repeat for each lock.

## Stacking Disassembly

- 1) Turn the stacking lock counter-clockwise to loosen.
- 2) The whole spring on the stacking lock should be in view to release each frame. The disengaged spring should release the stacking lock. If not, keep turning the stacking lock until it disengages.

Stacking

Push stacking lock into the slot of the upper frame, then spin the cap to tighten the lock.

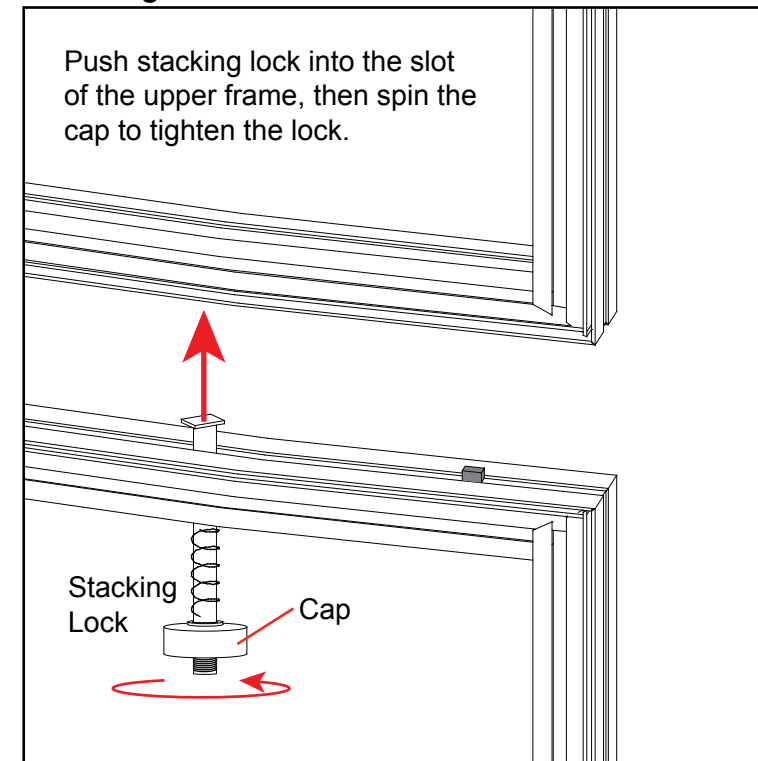

Unstacking

Disengage the stacking lock by spinning the cap counter clockwise and pulling down.

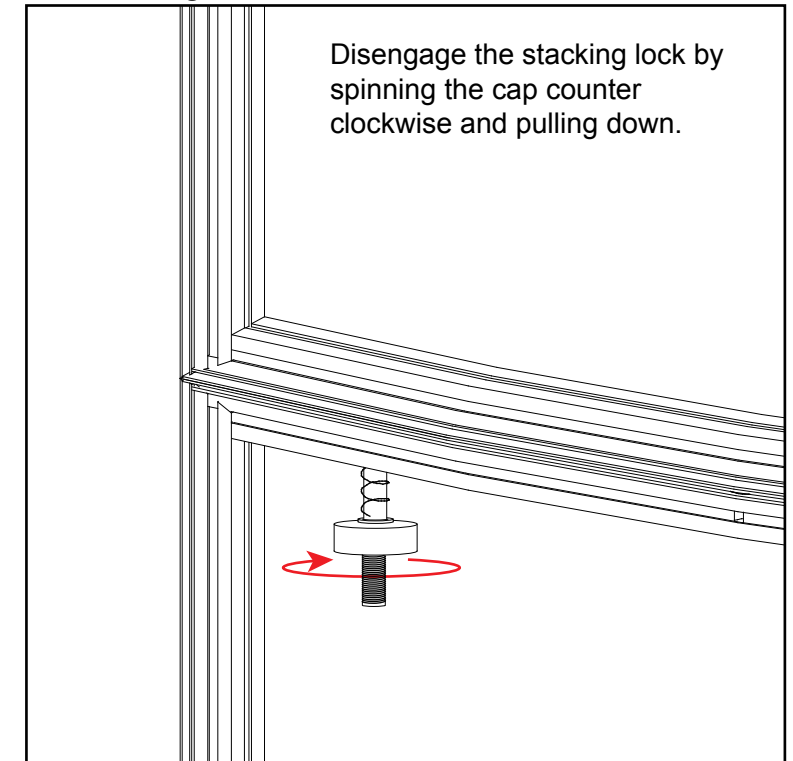

# SEG Graphic Installation *in 3 Steps*

*The Perfect Fit*

## STEP 1: Attach Corners

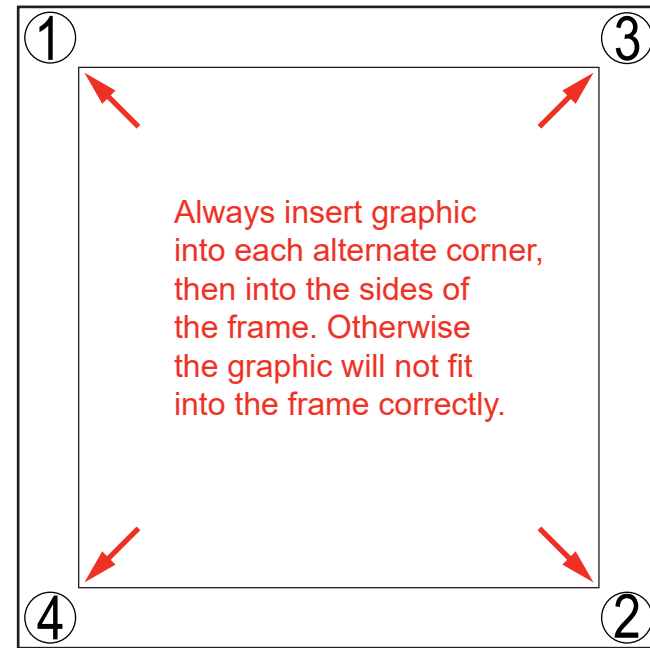

## STEP 2: Attach Middle

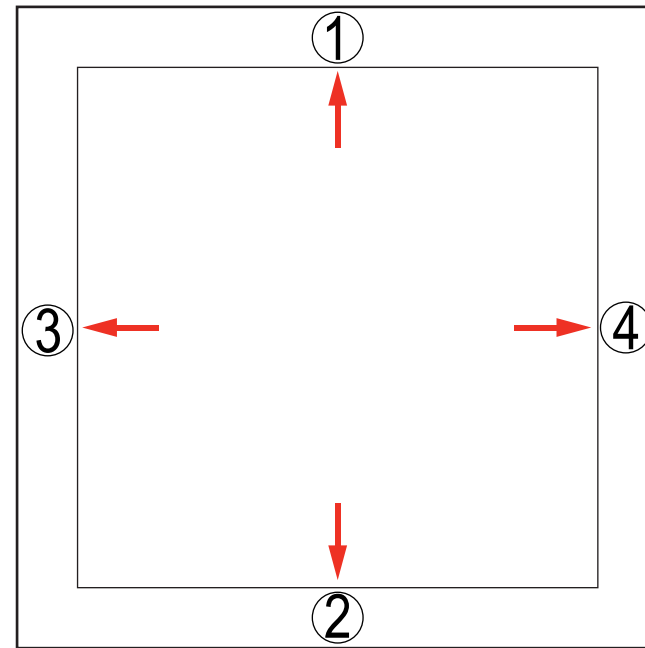

## STEP 3: Attach Sides

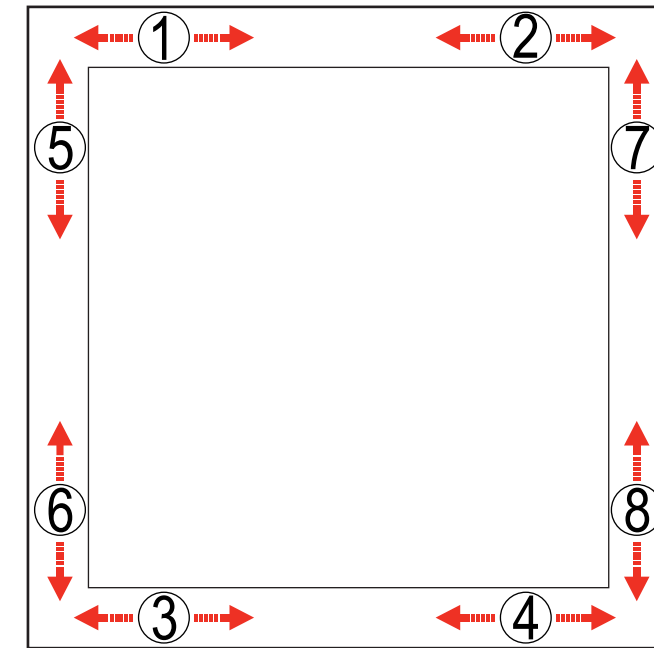

Insert narrow side of silicone welt into the channel at corner 1, with fabric to the outside.

Repeat for opposite corner 2, then corner 3, then corner 4.

Once corners are attached, press the middle of edge 1 into the channel. Then press middle of edge 2 into the channel on opposite side.

Repeat with edge 3 & 4.

Once the middle of sides are attached, fully press the silicone welt into the channel, between center and corner at location 1. Repeat the process between center and corner at location 2.

Do the same for welt on opposite side, at locations 3 & 4. Then repeat for locations 5 & 6 and 7 & 8.

Once the welt is fully inserted on all sides, smooth out edges as needed for a perfect fit.



To remove the graphic from the frame, locate the fabric **pull tab**. Gently pull on the tab to remove the graphic.

Install video:



CRATE PACKING

Item	Qty.	Description
1	1	14.125"w x 95"h Gravitee panel
2	1	94.5"h Gravitee corner post w/ caps
3	1	38"w x 95"h Gravitee lightbox panel
4	1	94.5"h Gravitee corner post w/ caps
5	1	14.125"w x 95"h Gravitee panel
6	1	95"h Gravitee corner post
7	1	32.5"w x 95"h Gravitee Panel w/ wood infill
8	1	95"h Gravitee corner post
9	1	14.125"w x 95"h Gravitee panel
10	1	94.5"h Gravitee corner post w/ caps
11	1	38"w x 95"h Gravitee panel w/ wood infill
12	1	94.5"h Gravitee corner post w/ caps
13	1	14.125"w x 95"h Gravitee panel

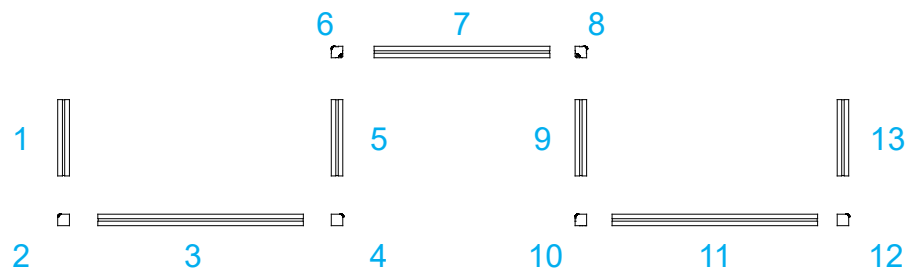

TOP VIEW

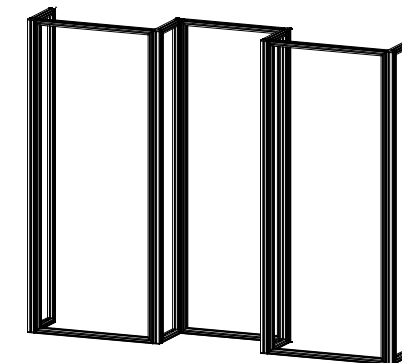

When assembled

Steps:  
1) Assemble Gravitee panels & posts in numerical order as shown. Refer to the Gravitee Assembly general information page.

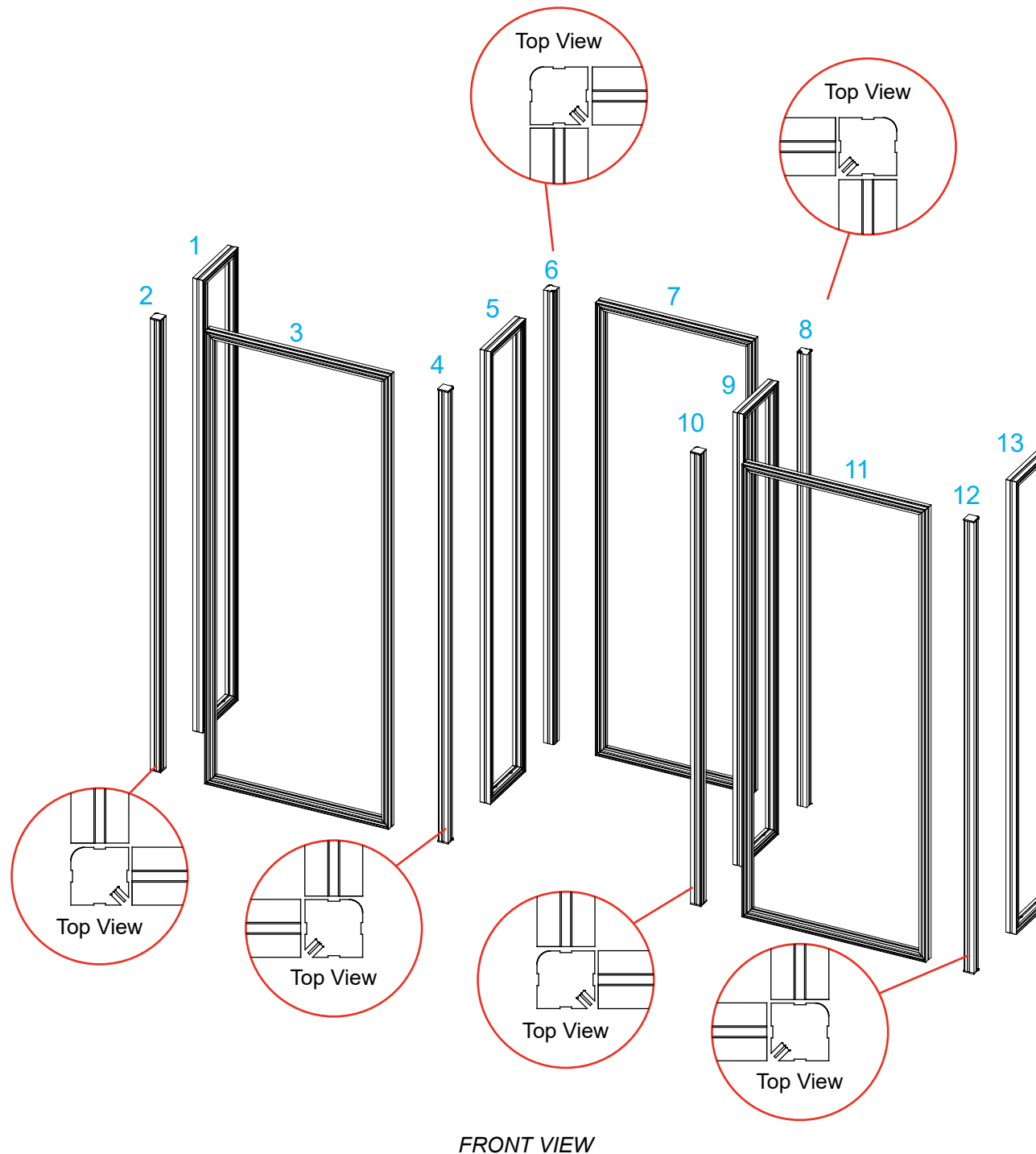

FRONT VIEW

Steps:

- 1) Connect power cords to LED lights in panels [3,11].  
See [Light Connection](#) detail.

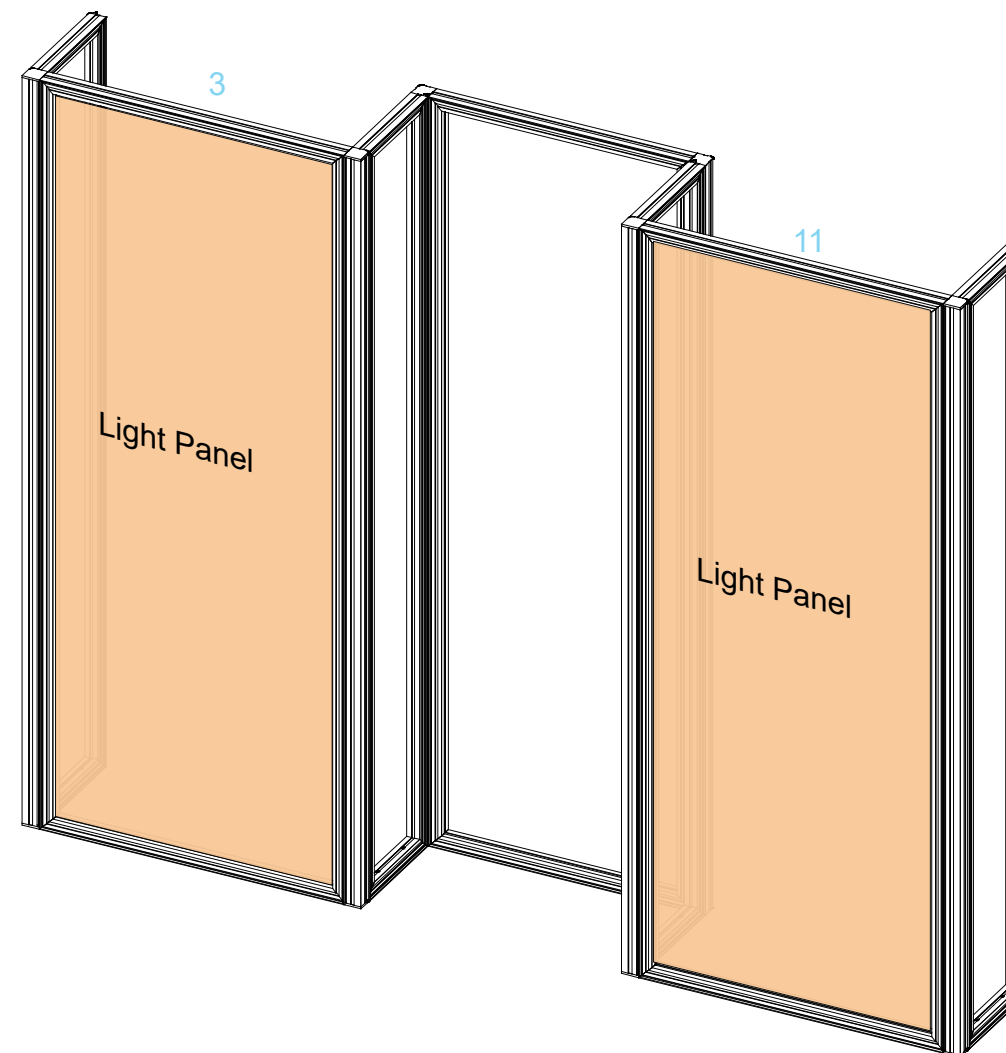
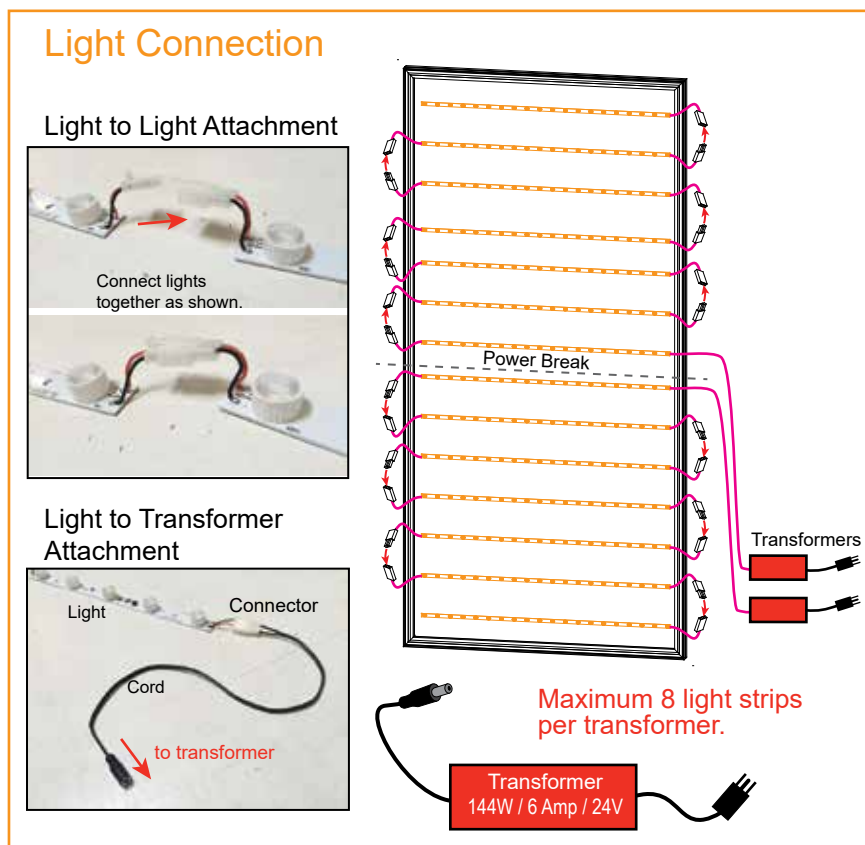

## SEG Graphic Installation

### STEP 1: Attach Corners

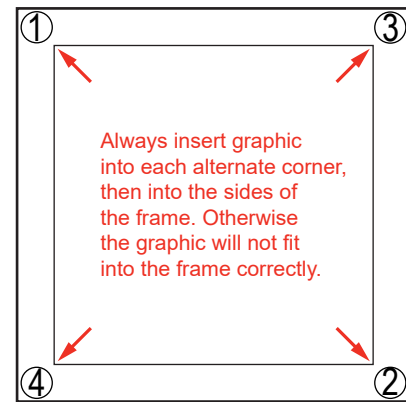

Insert narrow side of silicone welt into the channel at corner 1, with fabric to the outside.

Repeat for opposite corner 2, then corner 3, then corner 4.



### STEP 2: Attach Middle

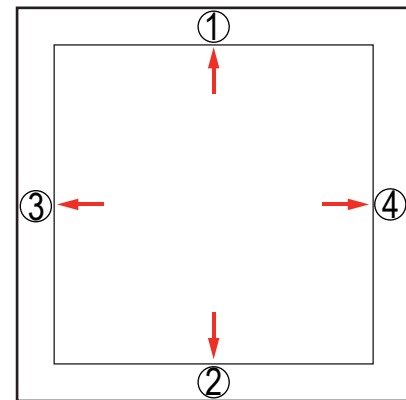

Once corners are attached, press the middle of edge 1 into the channel. Then press middle of edge 2 into the channel on opposite side.

Repeat with edge 3 & 4.

### STEP 3: Attach Sides

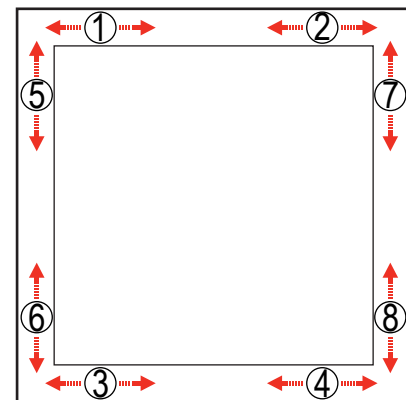

Once the middle of sides are attached, fully press the silicone welt into the channel, between center and corner at location 1. Repeat the process between center and corner at location 2.



To remove the graphic from the frame, locate the fabric pull tab. Gently pull on the tab to remove the graphic.

Do the same for welt on opposite side, at locations 3 & 4. Then repeat for locations 5 & 6 and 7 & 8.

Steps:

- 1) Apply SEG Graphics to panels as shown.
- 2) Attach Perf Light to top of panel [7]. See [Light Attachment](#) detail.

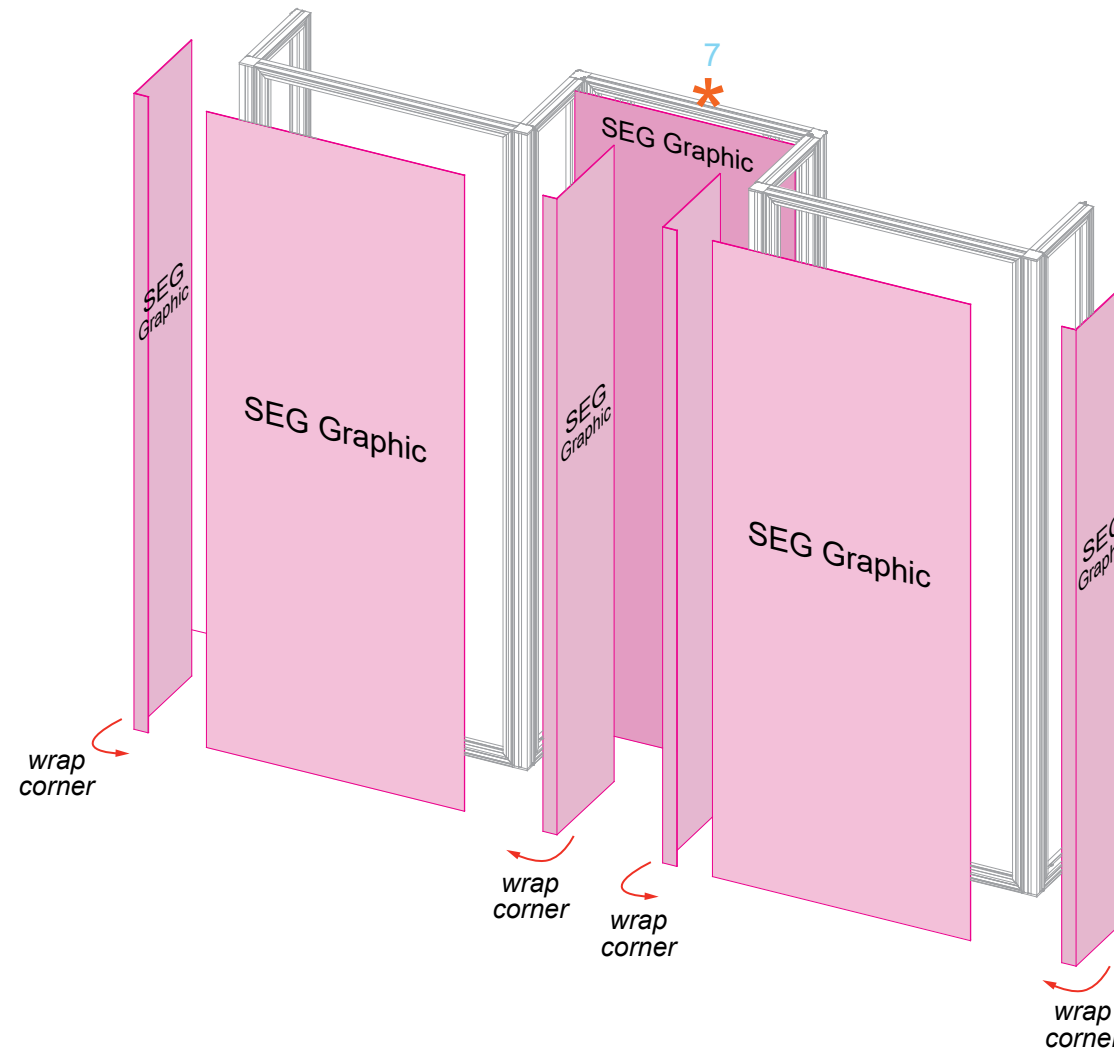

### \* Light Attachment

Attach lights to top of panel and tighten in place.

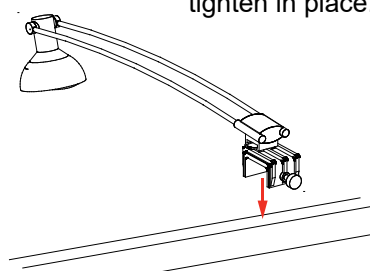

Item	Qty.	Description
--	4	32.25" w x 10" d Shelf w/ Z31

Steps:  
1) Attach Shelves to vertical extrusions in panel [7] as shown.  
See [Shelf Attachment](#) detail.

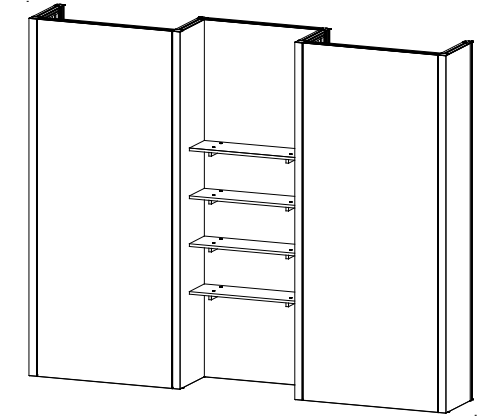

When assembled

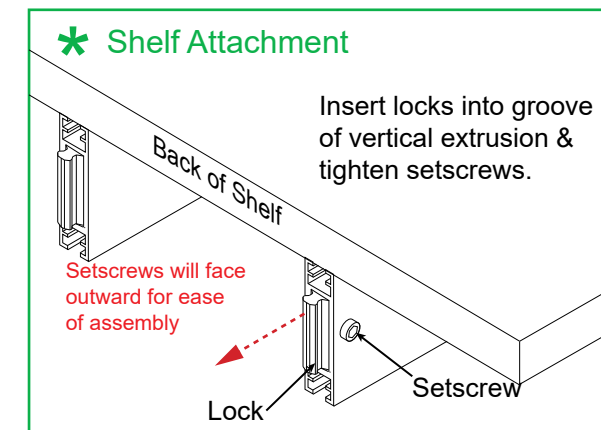
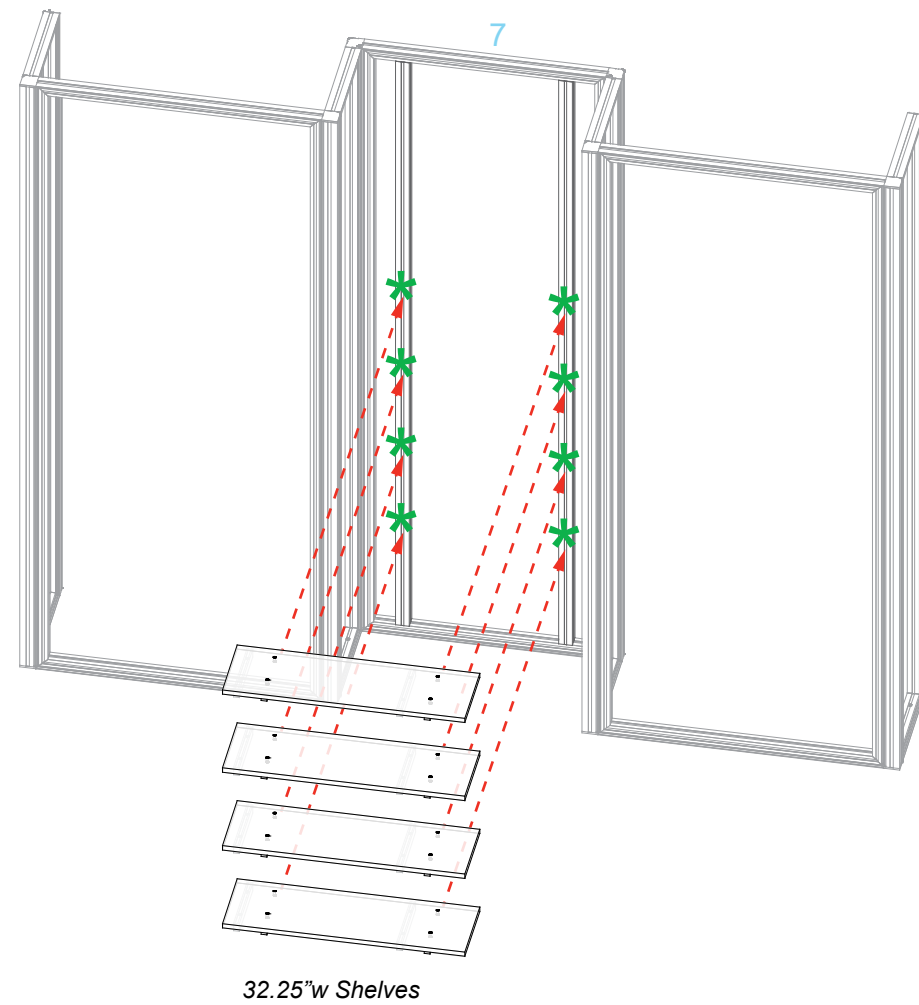

Item	Qty.	Description
14	1	38"h Gravitee Corner Post w/ Door Attachment
15	1	14.125"w x 38"h Gravitee Panel Frame
16	1	38"h Gravitee Corner Post
17	1	19"w x 38"h Gravitee Panel Frame
18	1	19"w x 38"h Gravitee Panel Frame
19	1	38"h Gravitee Corner Post
20	1	14.125"w x 38"h Gravitee Panel Frame
21	1	38"h Gravitee Corner Post w/ Door Attachment
9,9A	1,1	37.0945"w Z45 Horizontal Extrusion
10	1	34.4173"h Z45 Vertical Extrusion

Steps:

- 1) Assemble Gravitee panels and posts in numerical order, as shown, making sure Velcro is facing inward. Refer to the Gravitee Assembly general information page.
- 2) Attach horizontal extrusions [9] and [9A] between posts [14] and [21].
- 3) Attach vertical [10] between horizontals [9] and [9A].
- 4) Connect doors to posts [14] and [21]. See **Door Connection** detail.

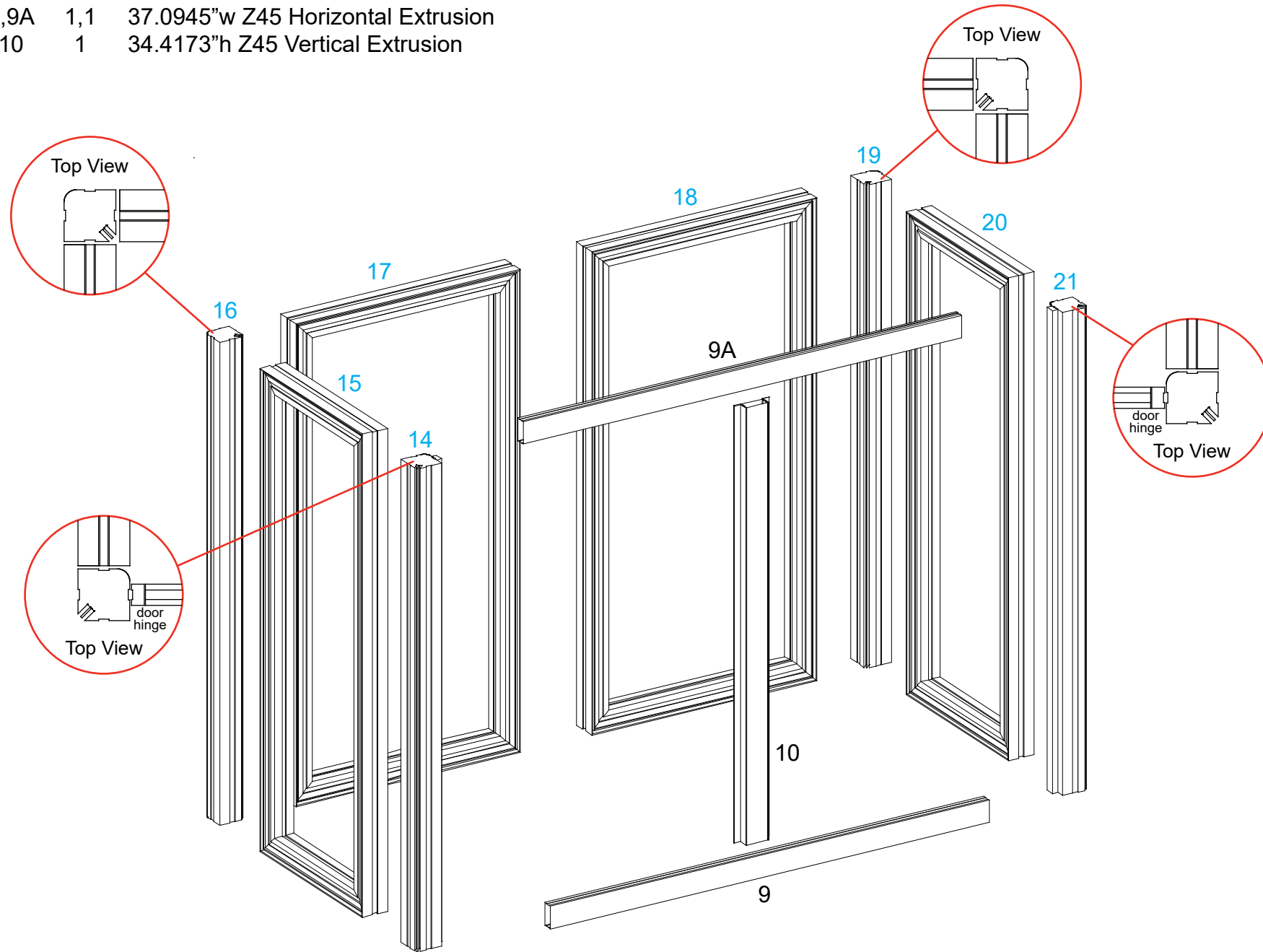
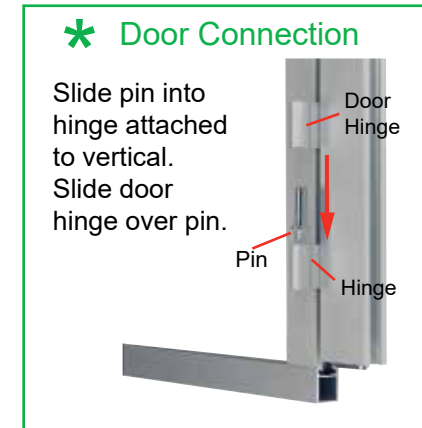

Back View

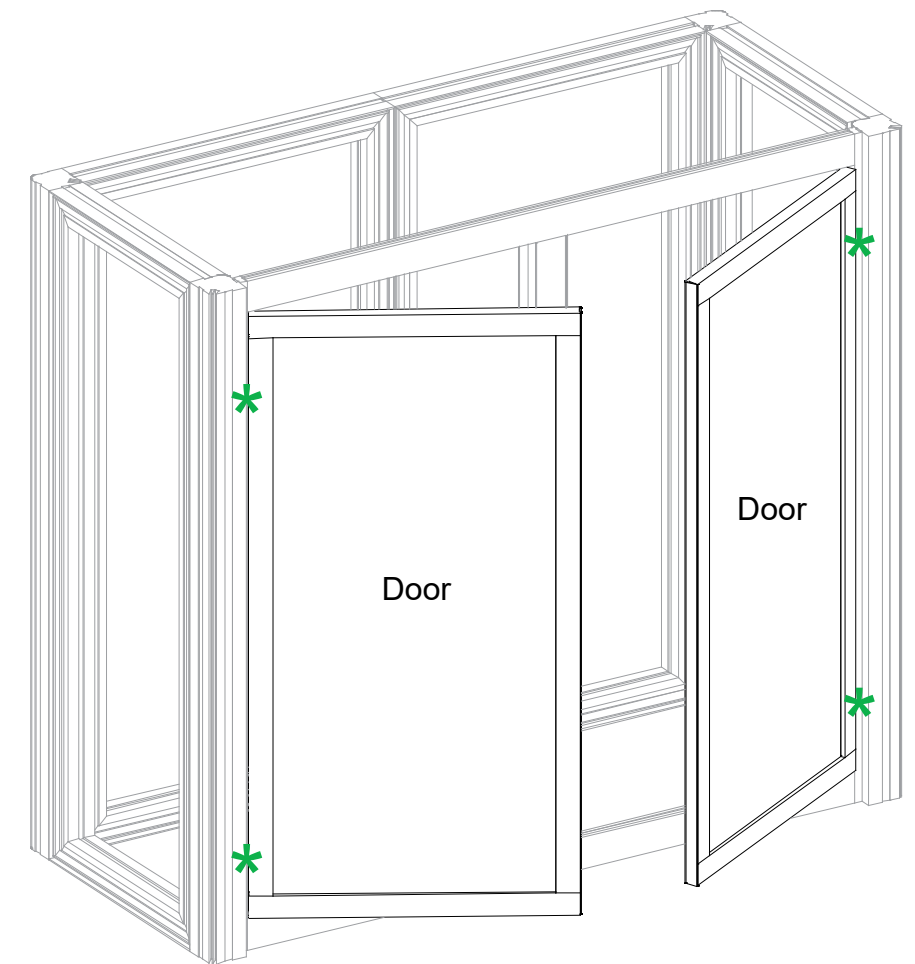

Back View

Steps:

- 1) Wrap **SEG Graphic** around front and sides of assembled counter.  
See SEG Graphic Installation sheet for instruction.
- 2) Connect shelf supports to Velcro, then place shelf on top of supports.
- 3) Lock counter top to panels [15] and [20]. See **Counter Top Lock** detail.

Keep connectors [14] [21] extrusions [9] [9A] [10] and doors assembled, when packing.

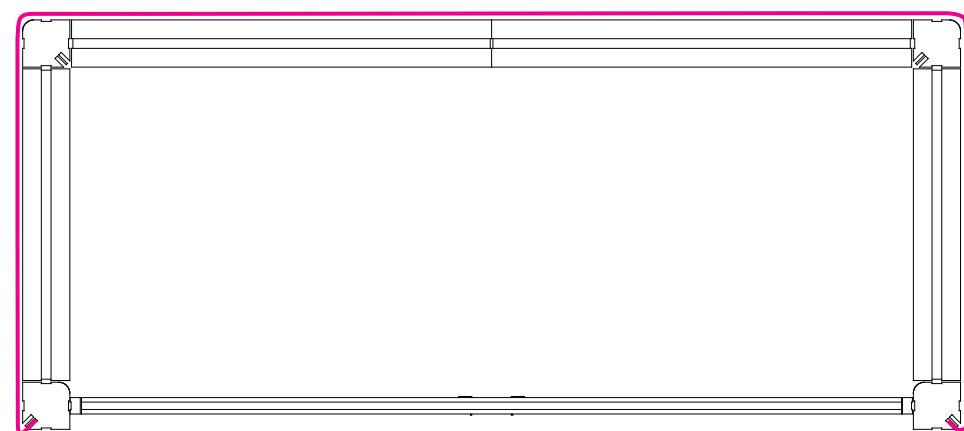

Top View

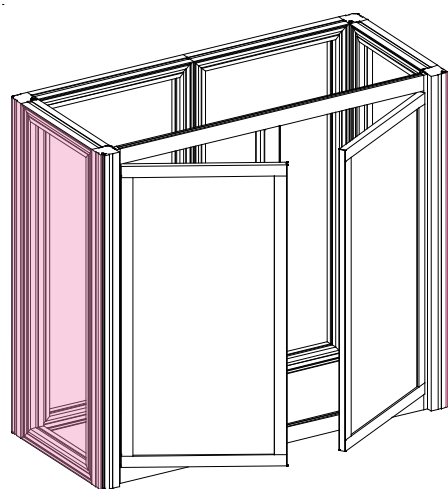

Back View

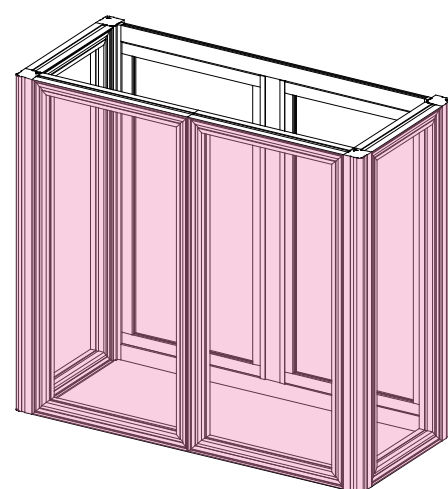

Front View

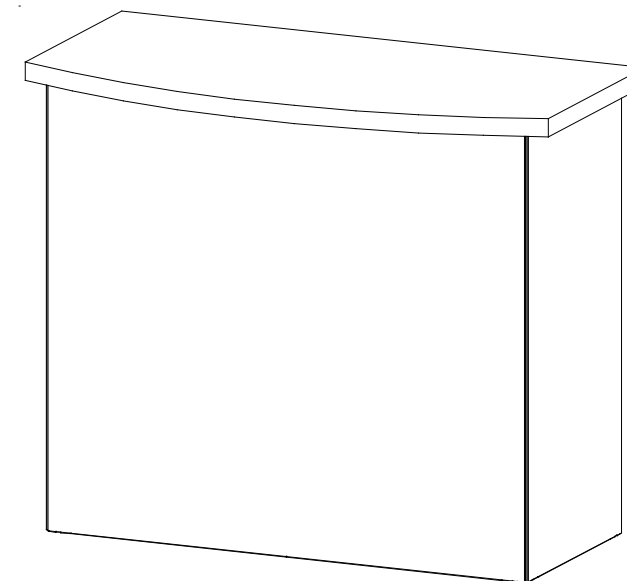
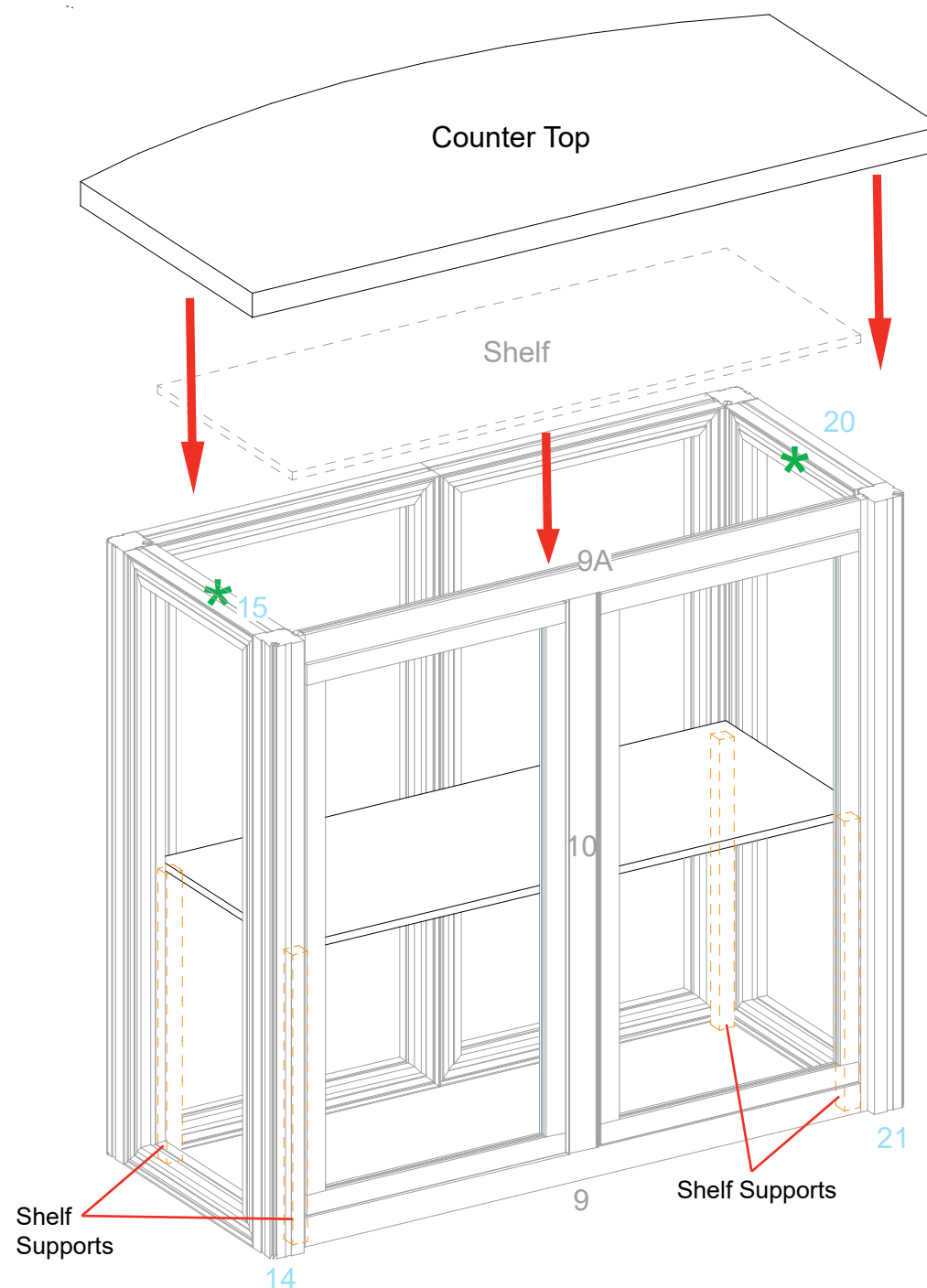

Completed Assembly

