

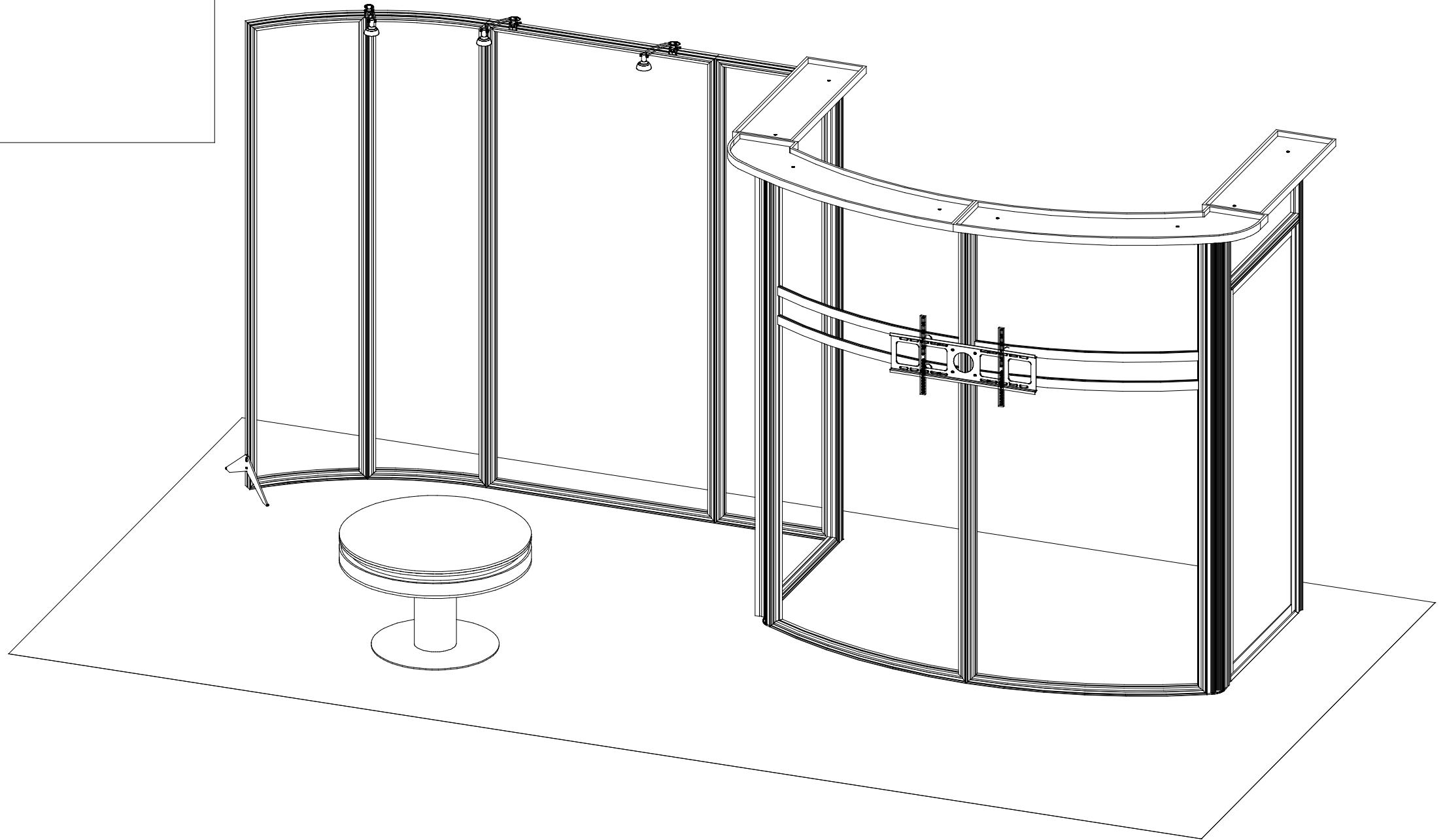

Plan View

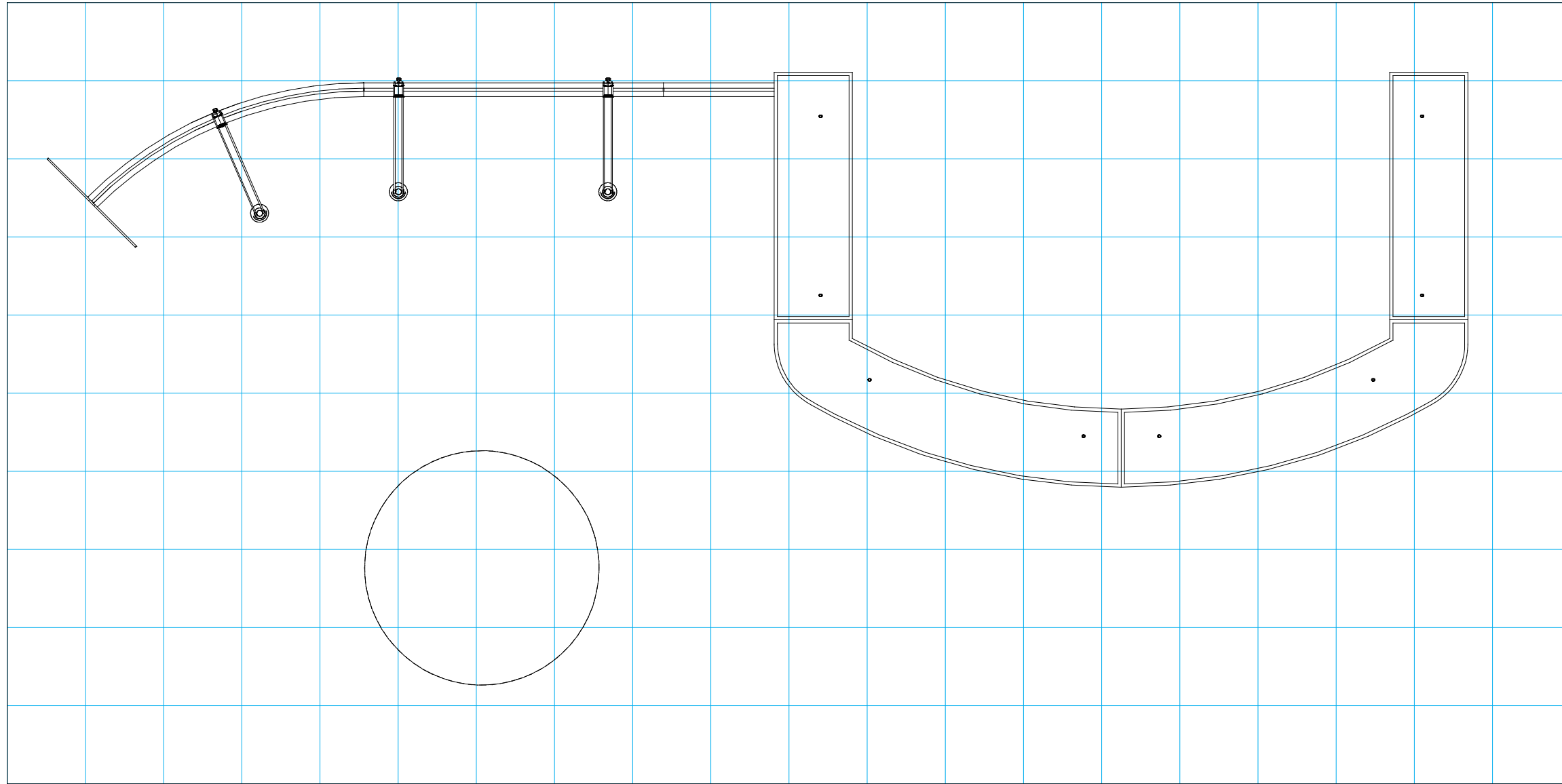

SETUP INSTRUCTIONS



 = 1 sq foot

General Setup Instructions

- Read entire setup instruction manual prior to unpacking parts and pieces.
- The setup instructions are created specifically for this configuration.
- Setup instructions are laid out sequentially in steps, including exploded views with detailed explanation for assembly.

Cleaning & Packing

- For Cleaning Metal, Plex, & Laminate Parts: Use a **MILD NON-ABRASIVE** cleanser and soft cloth/paper towel to clean all surfaces.
- Keep exhibit components away from heat and prolonged sun exposure. **Heat and UV exposure will warp and fade components.**
- Retain all provided Packing Materials. All provided packing materials are for ease of repacking & component protection.

Disassembly

- For loss prevention, tighten all set screws and locks during disassembly.

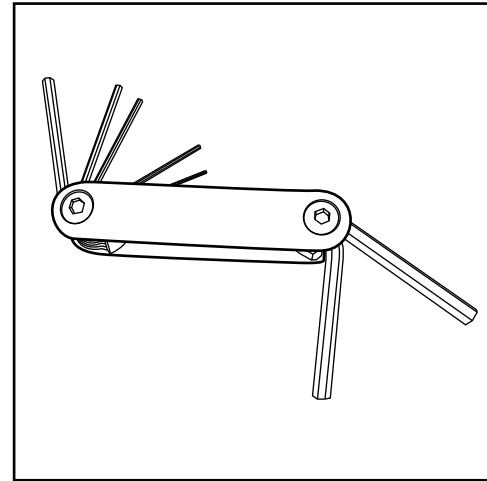

Hex Tool - Essential for Assembly

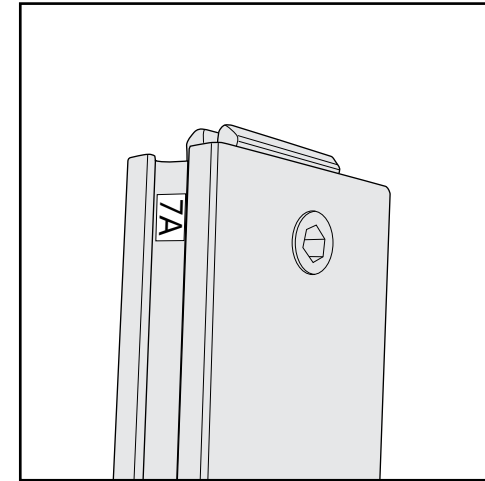

Part Identification - Numbering

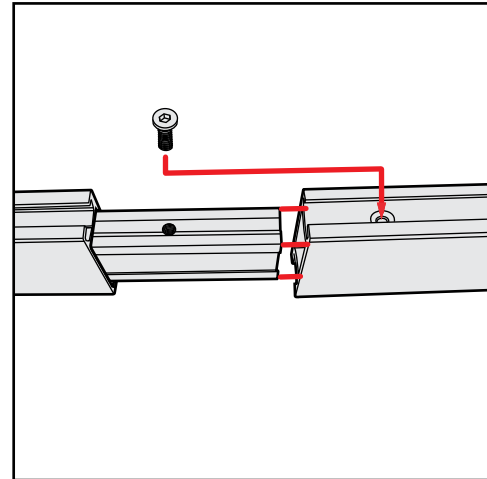

Spline Connection

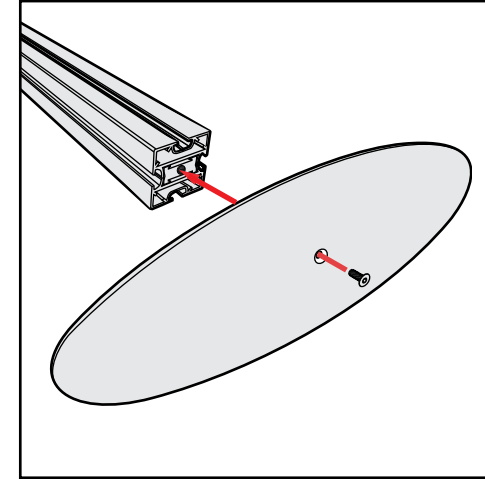

Base Plate & Extrusion Connection

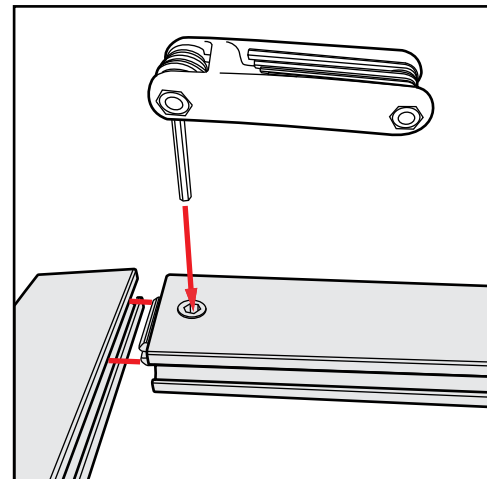

Extrusion & Lock Connection

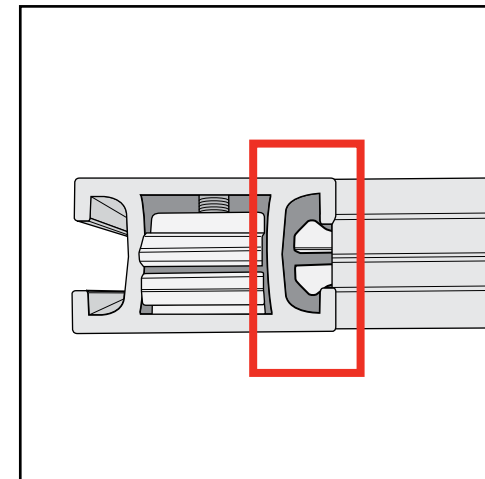

Engaged Lock



WARNING

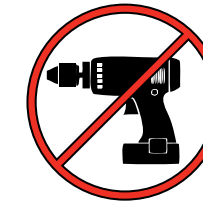

DO NOT USE POWER TOOLS

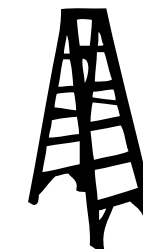

LADDERS OR LIFTS
MAY BE REQUIRED



ALL CONNECTIONS MUST
BE TIGHTLY SECURED

Side-by-Side Assembly

- 1) Frames: Place frames side-by-side with one higher than the other, then slide panel down to lock panels securely together.
- 2) Corner Connectors: Repeat Step 1 for installing corner connectors to frames.

Side-by-Side Disassembly

- 1) Pull pin lock outwards to disengage.
- 2) Pull frames upward and apart at the same time to detach.

Assembly

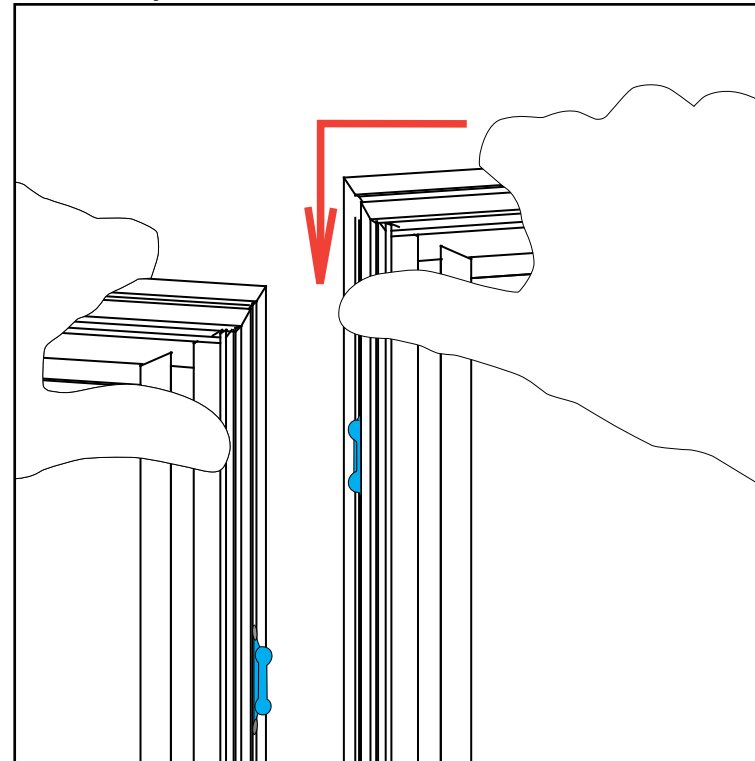

Assembly Cont'd

Push pin lock into hole of connecting frame.
Note: Block of pin lock will secure in groove.

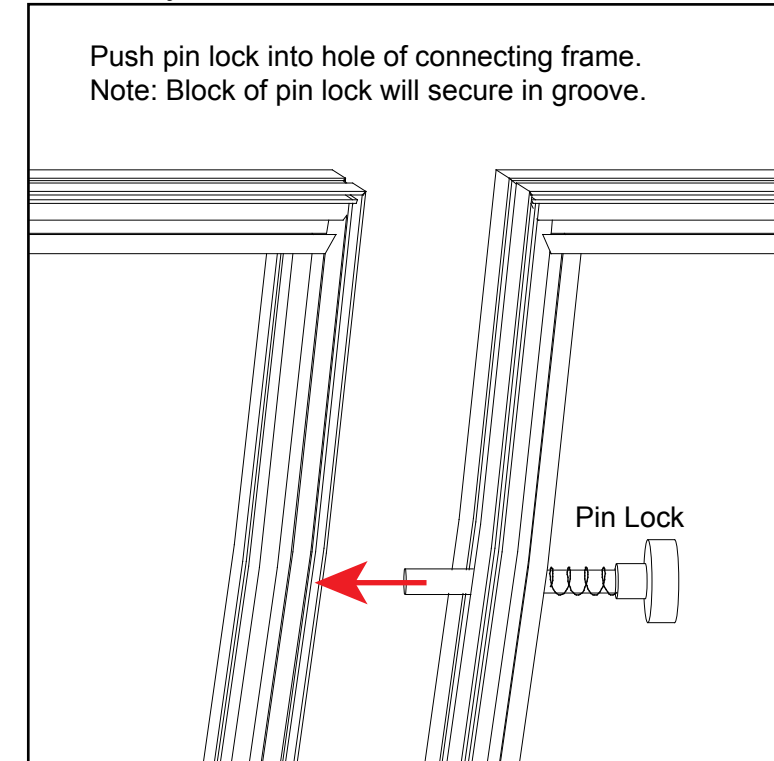

Corner Connector

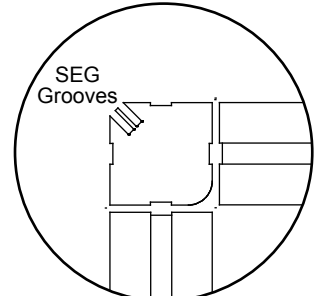

Top View
Note: Orientation of Corner Connector may change.

Stacking Assembly

- 1) Place one horizontal frame on top of the other, lining up the center grooves.
- 2) Turn stacking lock clockwise to tighten into place. Repeat for each lock.

Stacking Disassembly

- 1) Turn the stacking lock counter-clockwise to loosen.
- 2) The whole spring on the stacking lock should be in view to release each frame. The disengaged spring should release the stacking lock. If not, keep turning the stacking lock until it disengages.

Stacking

Push stacking lock into the slot of the upper frame, then spin the cap to tighten the lock.

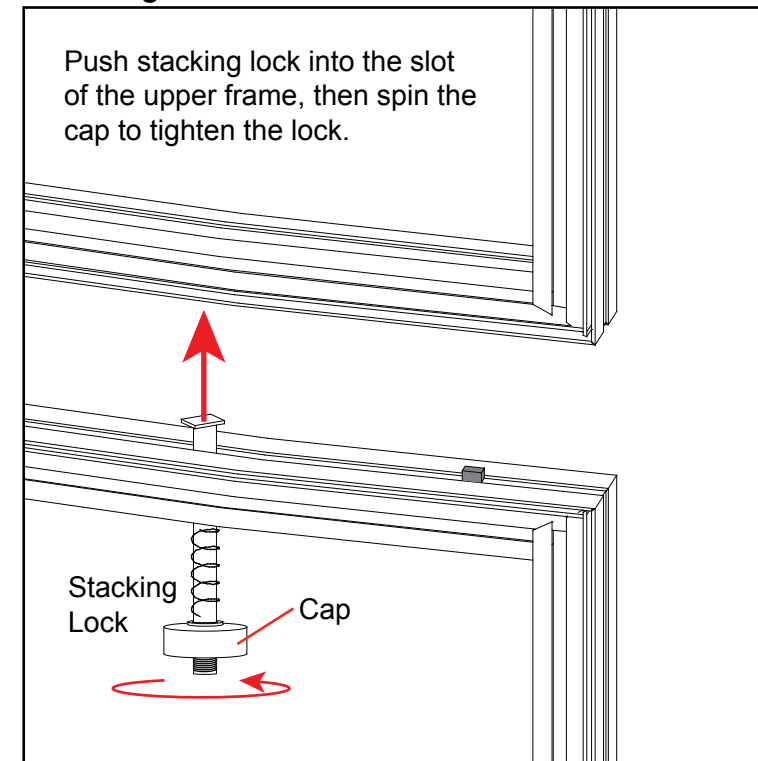

Unstacking

Disengage the stacking lock by spinning the cap counter clockwise and pulling down.

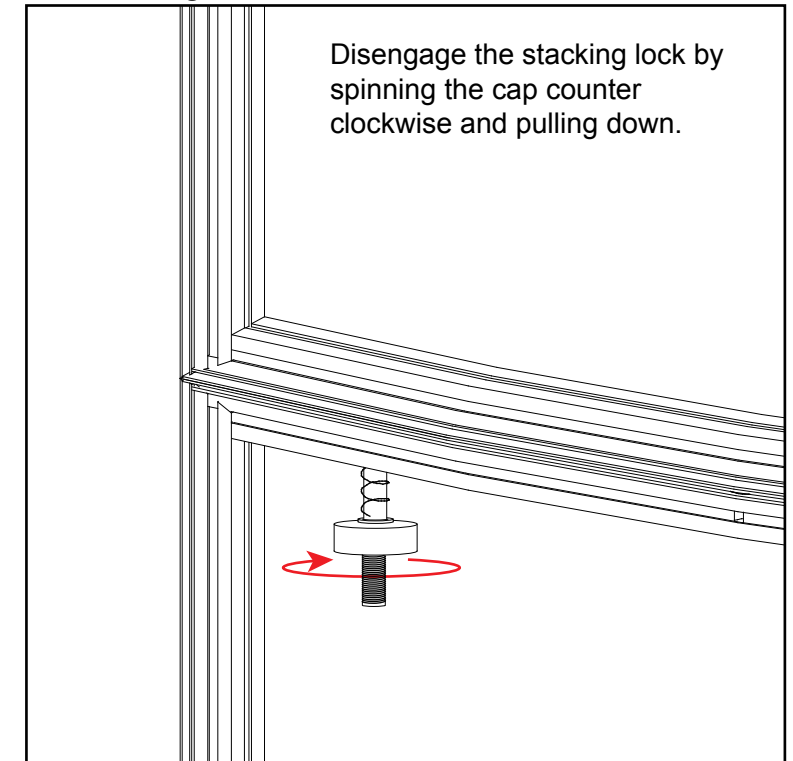

SEG Graphic Installation *in 3 Steps*

The Perfect Fit

STEP 1: Attach Corners

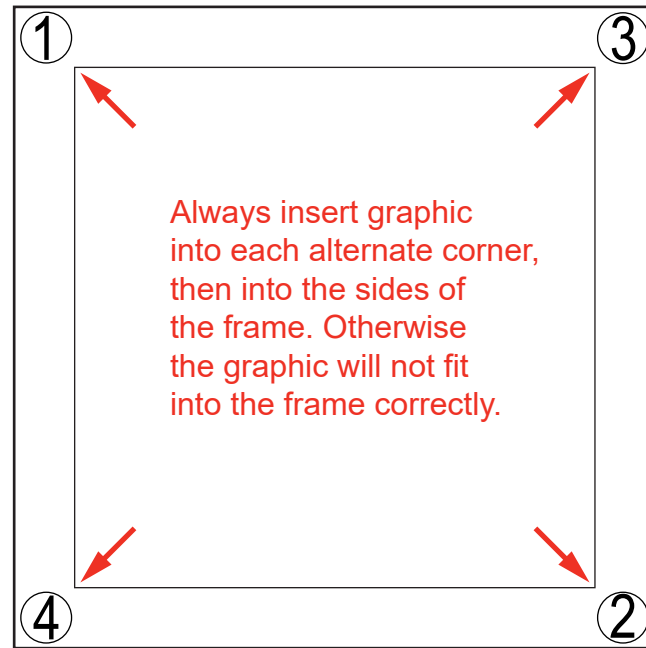

STEP 2: Attach Middle

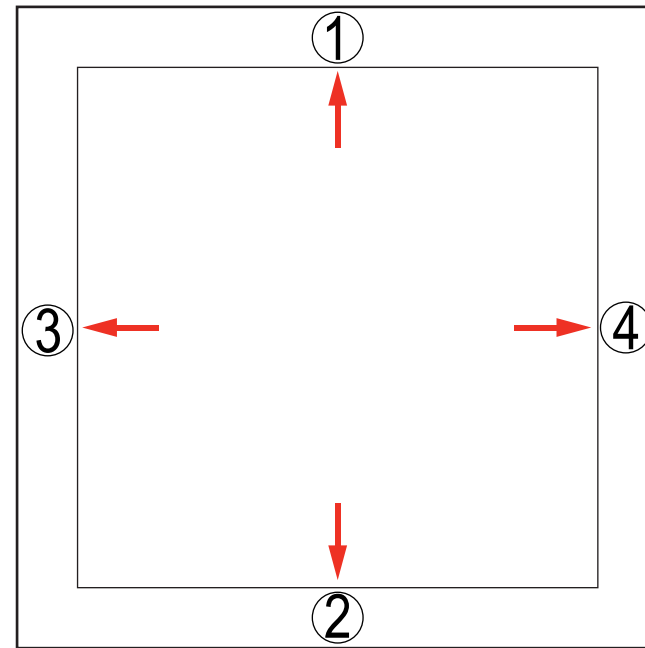

STEP 3: Attach Sides

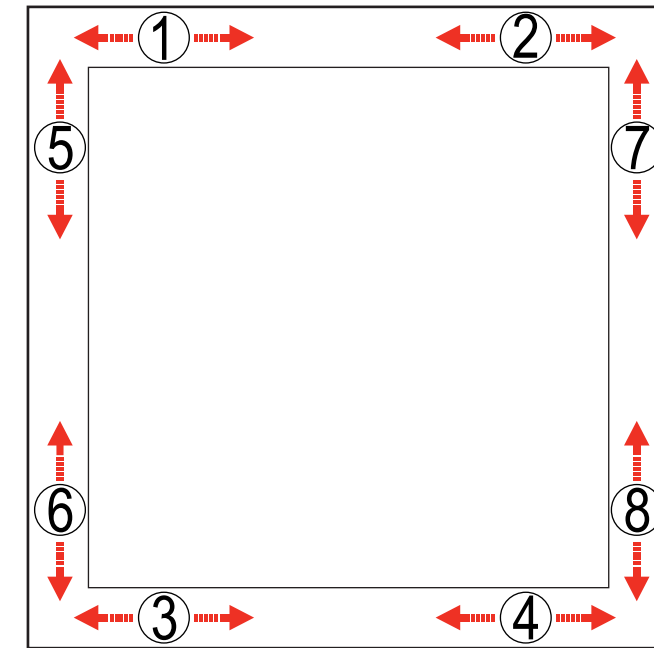

Insert narrow side of silicone welt into the channel at corner 1, with fabric to the outside.

Repeat for opposite corner 2, then corner 3, then corner 4.

Once corners are attached, press the middle of edge 1 into the channel. Then press middle of edge 2 into the channel on opposite side.

Repeat with edge 3 & 4.

Once the middle of sides are attached, fully press the silicone welt into the channel, between center and corner at location 1. Repeat the process between center and corner at location 2.

Do the same for welt on opposite side, at locations 3 & 4. Then repeat for locations 5 & 6 and 7 & 8.

Once the welt is fully inserted on all sides, smooth out edges as needed for a perfect fit.



To remove the graphic from the frame, locate the fabric **pull tab**. Gently pull on the tab to remove the graphic.

Install video:



CRATE PACKING

Item	Qty.	Description
1	1	38" w x 95" h Gravitee Door Panel
2	1	95" h Gravitee Corner Post
3	1	94.5" h Gravitee Hinged Connector
4	1	46" w x 95" h Gravitee curved Panel
5	1	46" w x 95" h Gravitee curved Panel
6	1	94.5" h Gravitee Hinged Connector
7	1	38" x 95" h Gravitee Panel
8	1	95" h Gravitee Corner Post
10	1	23" w x 95" h Gravitee Panel
11	1	46" w x 95" h Gravitee Panel
12	1	23" w x 95" h Gravitee curved Panel
13	1	23" w x 95" h Gravitee curved Panel
14	4	42.6179" w Z45 Horizontal Extrusion

Steps:

- 1) Assemble Gravitee panels & connectors together in numerical order as shown.
- 2) Attach horizontal extrusions [14] inside panels [4] and [5].
- 3) Attach Foot to Panel [13]. See [Foot Attachment](#) detail.

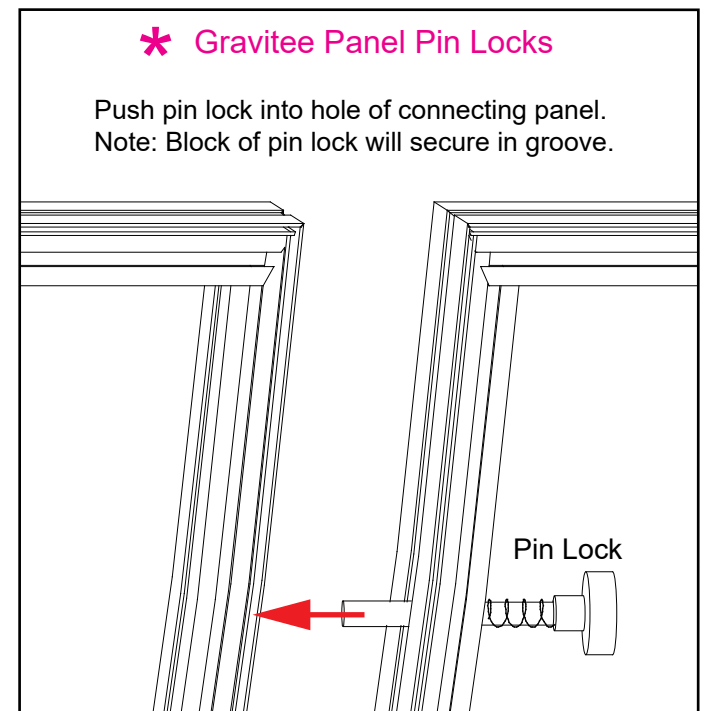
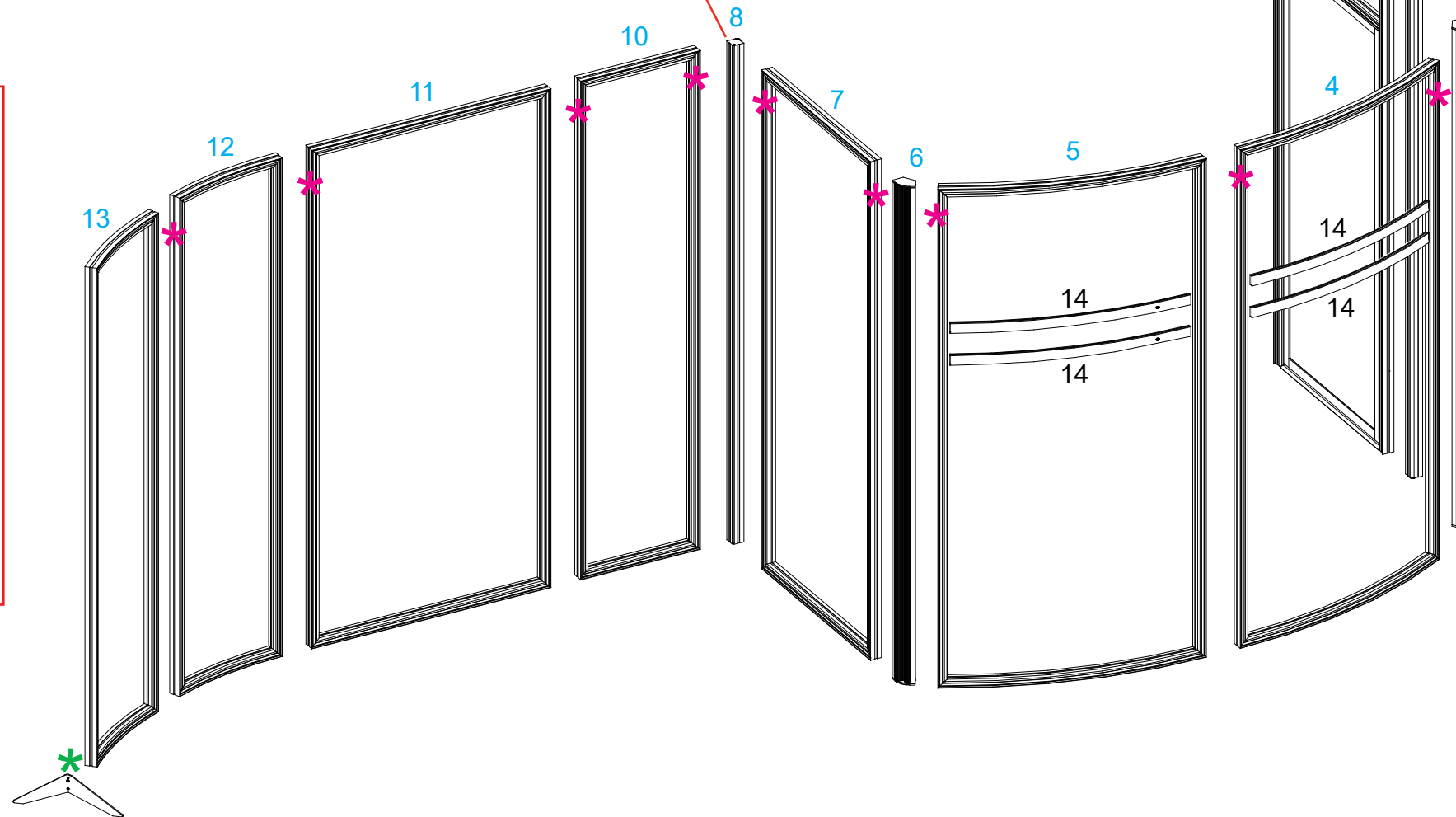
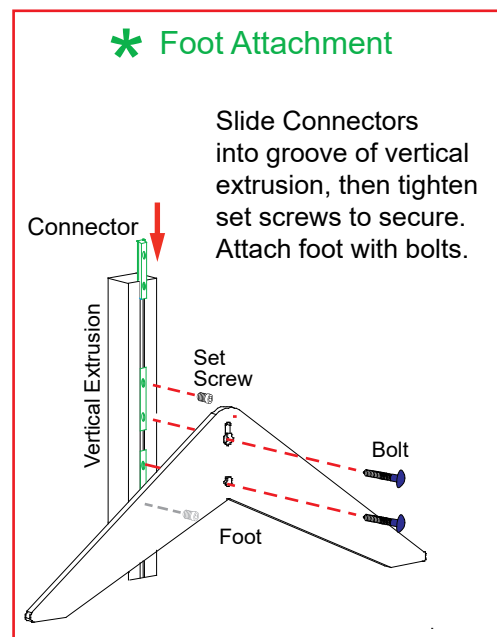
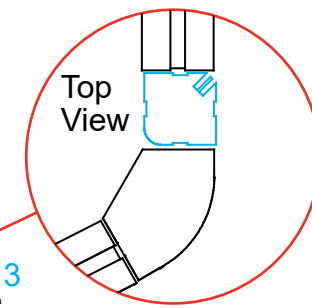
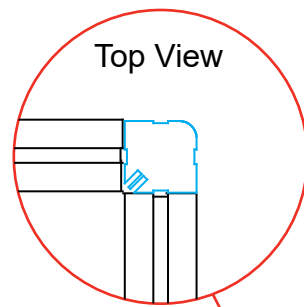
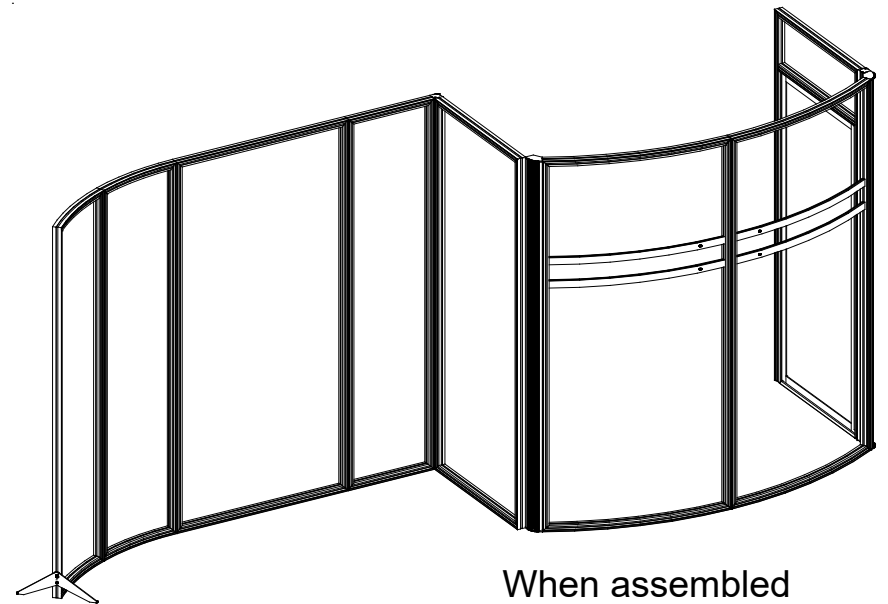

Steps:

- 1) Apply SEG graphics to front of assembled Backwall.
- 2) Insert Sintra graphic into assembled Backwall door frame.
- 3) Connect Sintra graphic to Velcro on front of assembled Backwall door section.

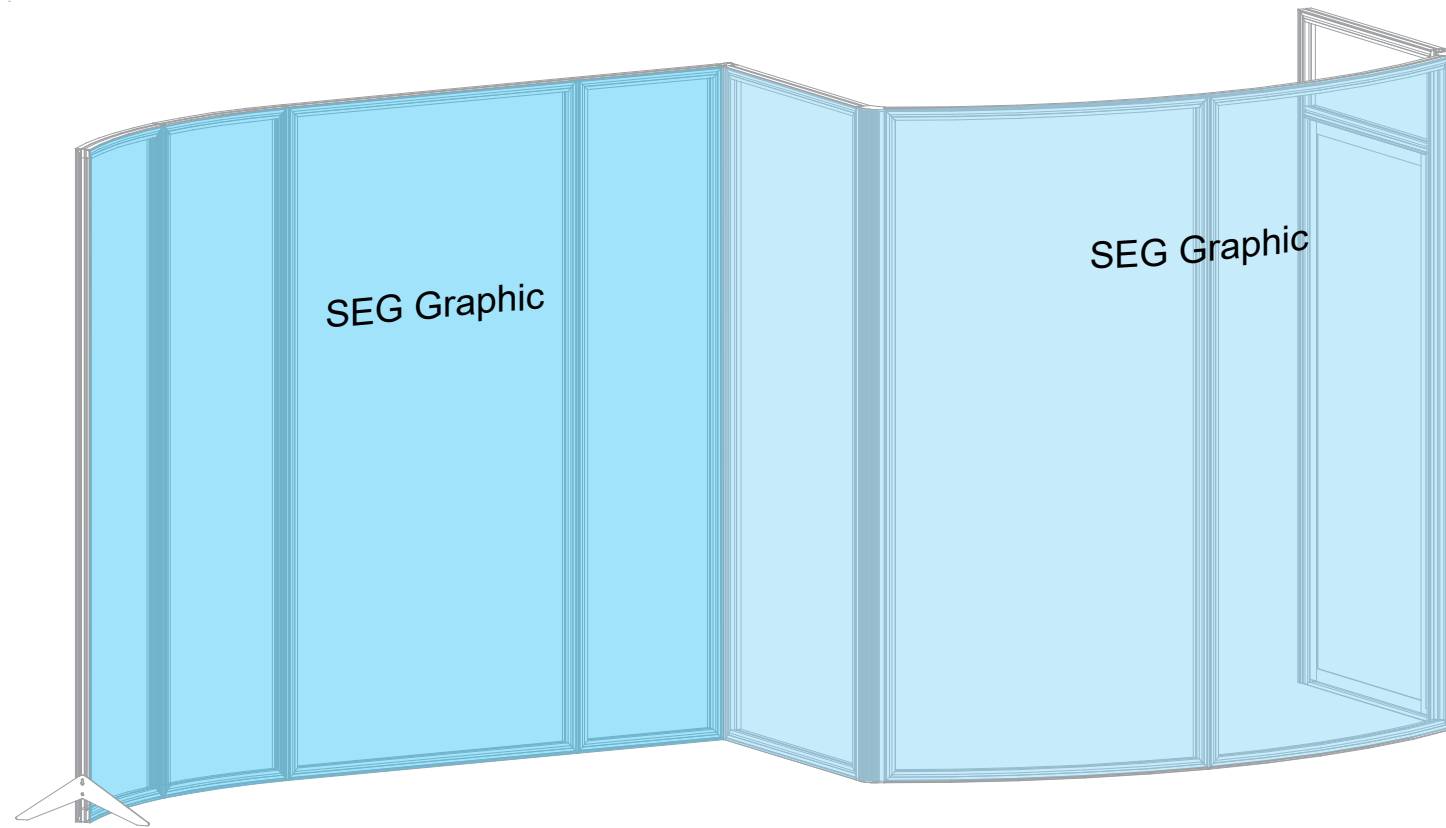

Front View

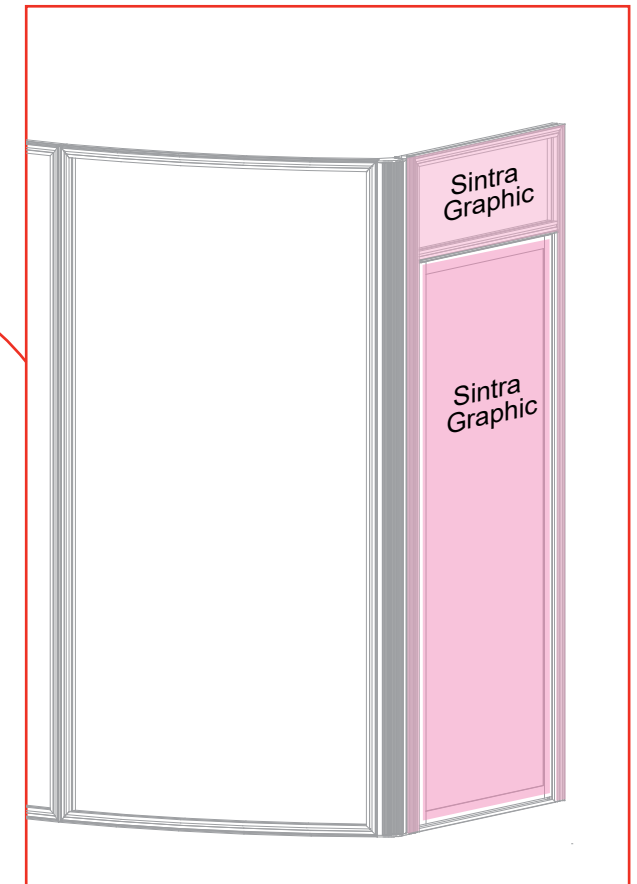

SEG Graphic Installation

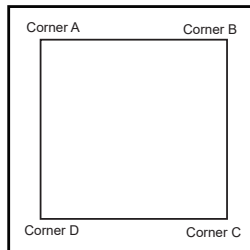

It is important to first insert graphic into each alternate corner then to the sides of the frame. If this is not done, graphic will not fit into the frame correctly.



Step 1
Insert corner A. Turn edge of graphic so silicon welt is perpendicular to face of graphic. Insert narrow side of welt with fabric to outside into the channel. Repeat for other side of this corner.



Step 2
Repeat Step 1 for opposite corner C, then insert corner D, to complete the installation of the corners.



Step 3
Once all corners are inserted, press one silicon edge into channel from corners and work toward the center. Make sure welt is fully inserted into channel. Continue until all sides are done. Smooth out edges of graphic.



Graphic Removal
To remove the graphic from the frame, locate the fabric pull tab. Gently pull up on the tab to remove the fabric.

Item	Qty.	Description
A	1	12' x 38" Canopy Panel
B	1	53.24" x 25.717" Canopy Panel
C	1	53.24" x 25.717" Canopy Panel
D	1	12' x 38" Canopy Panel

- Steps:
- 1) Install Canopy Panels [A,B,C,D] to top of Gravitee panels [1,4,5,7]. See **Canopy Attachment** detail.
 - 2) Attach Lights to Backwall. See **Light Connection** detail.
 - 3) Attach Monitor Mount to Backwall extrusions [14]. See **Monitor Mount Attachment** detail.

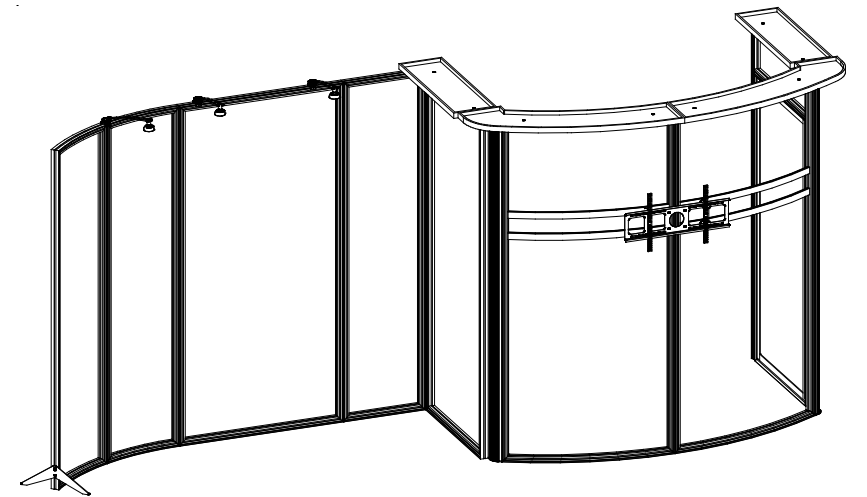

When assembled

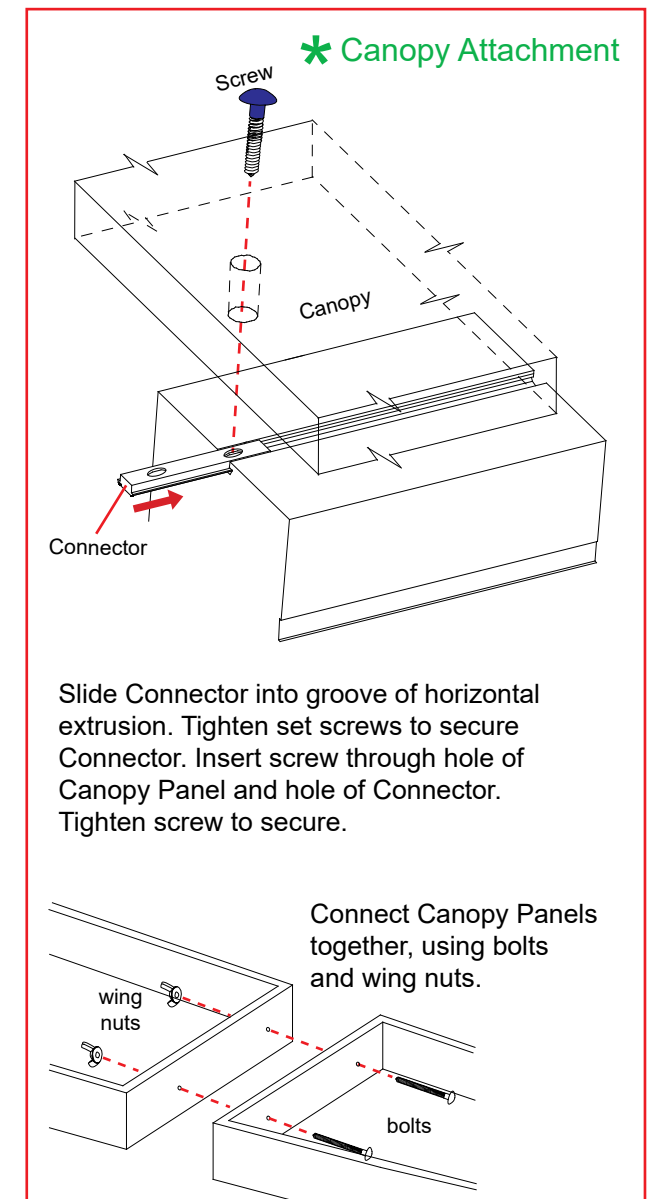
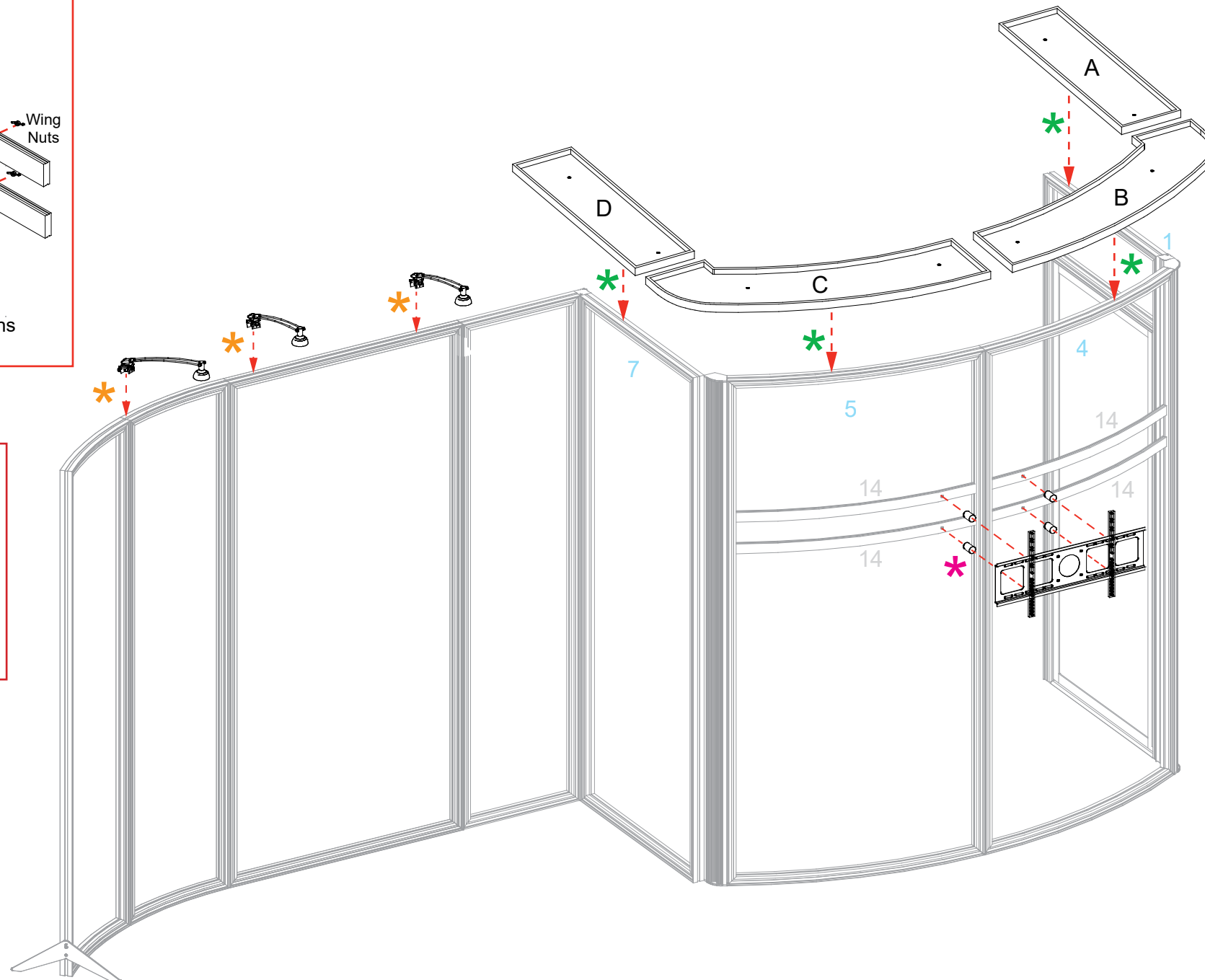
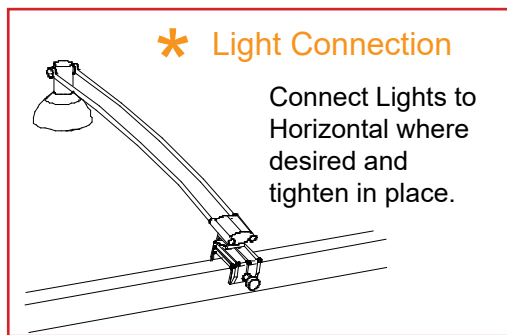
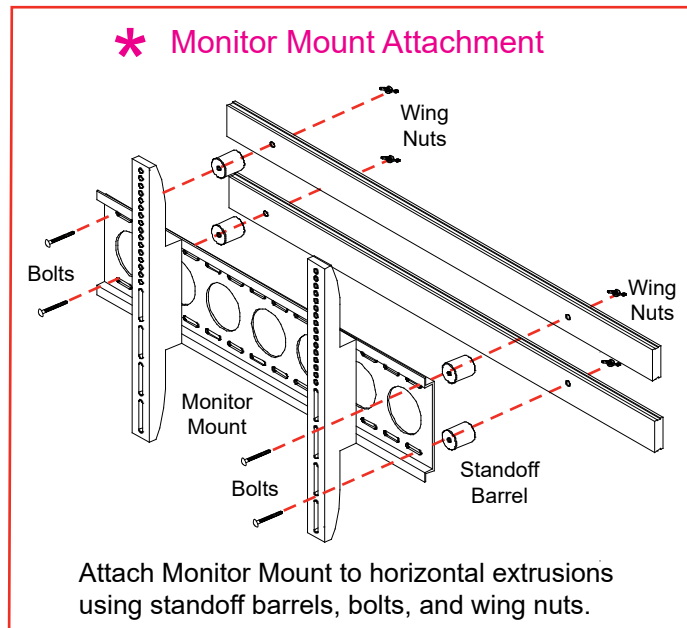

Steps:

- 1) Connect Base to Center Post, using bolt.
- 2) Feed cord, from Table Top, through Center Post and Base.
- 3) Connect Table Top to Center Post with fixed brackets and bolts.

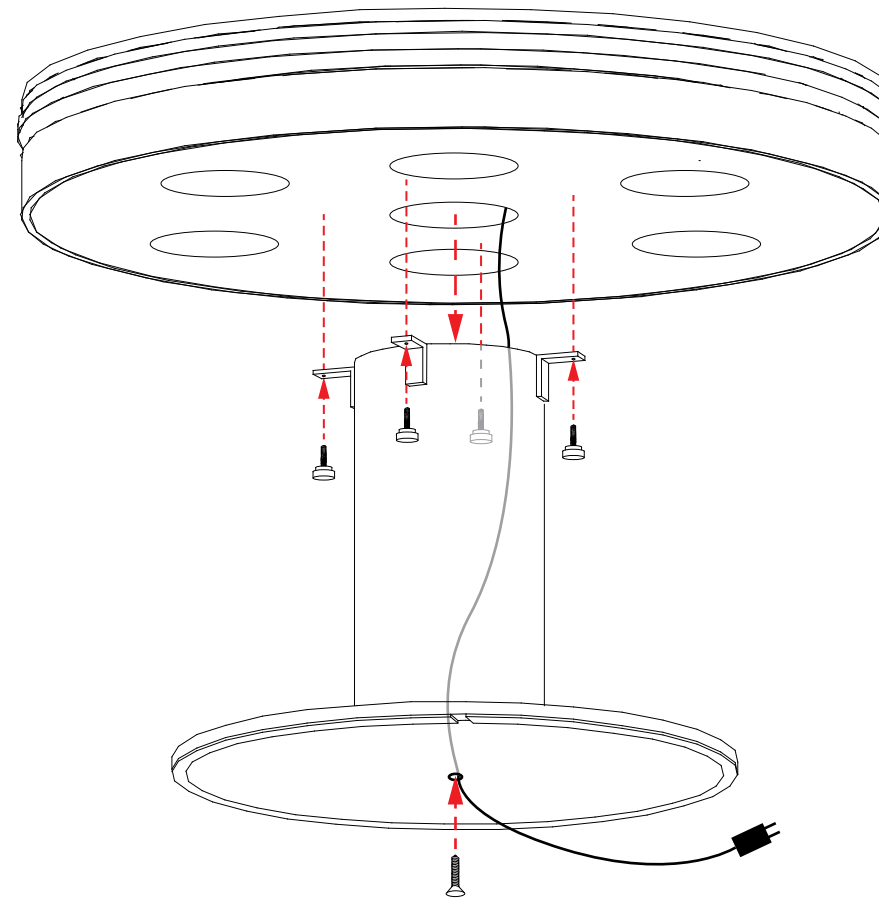
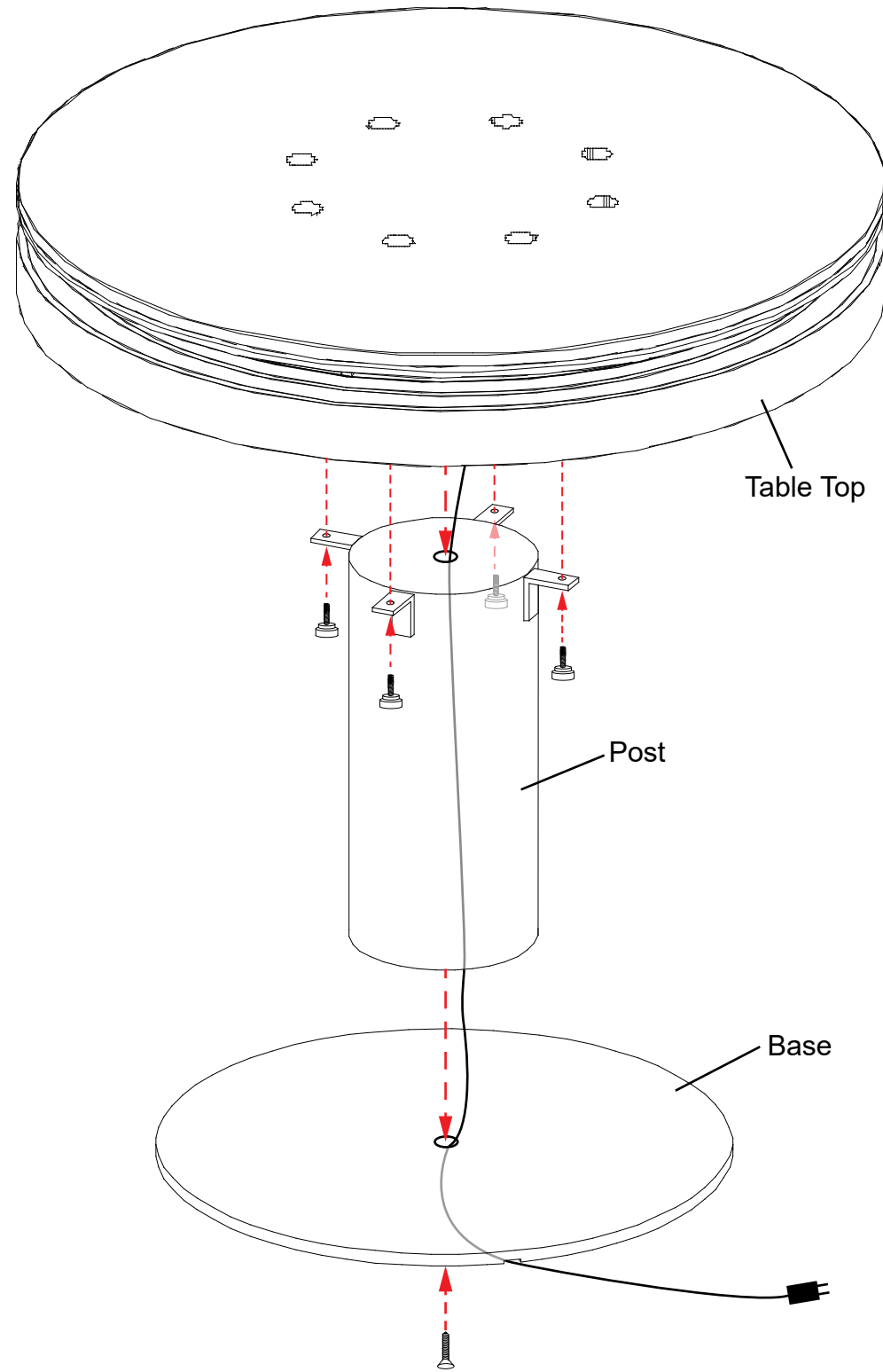

Underside View

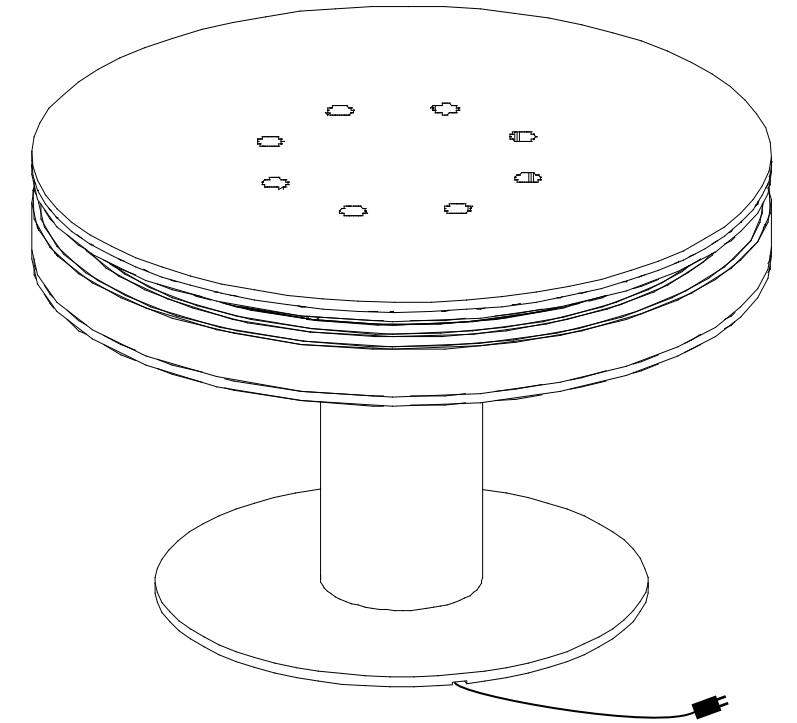

Completed Assembly