

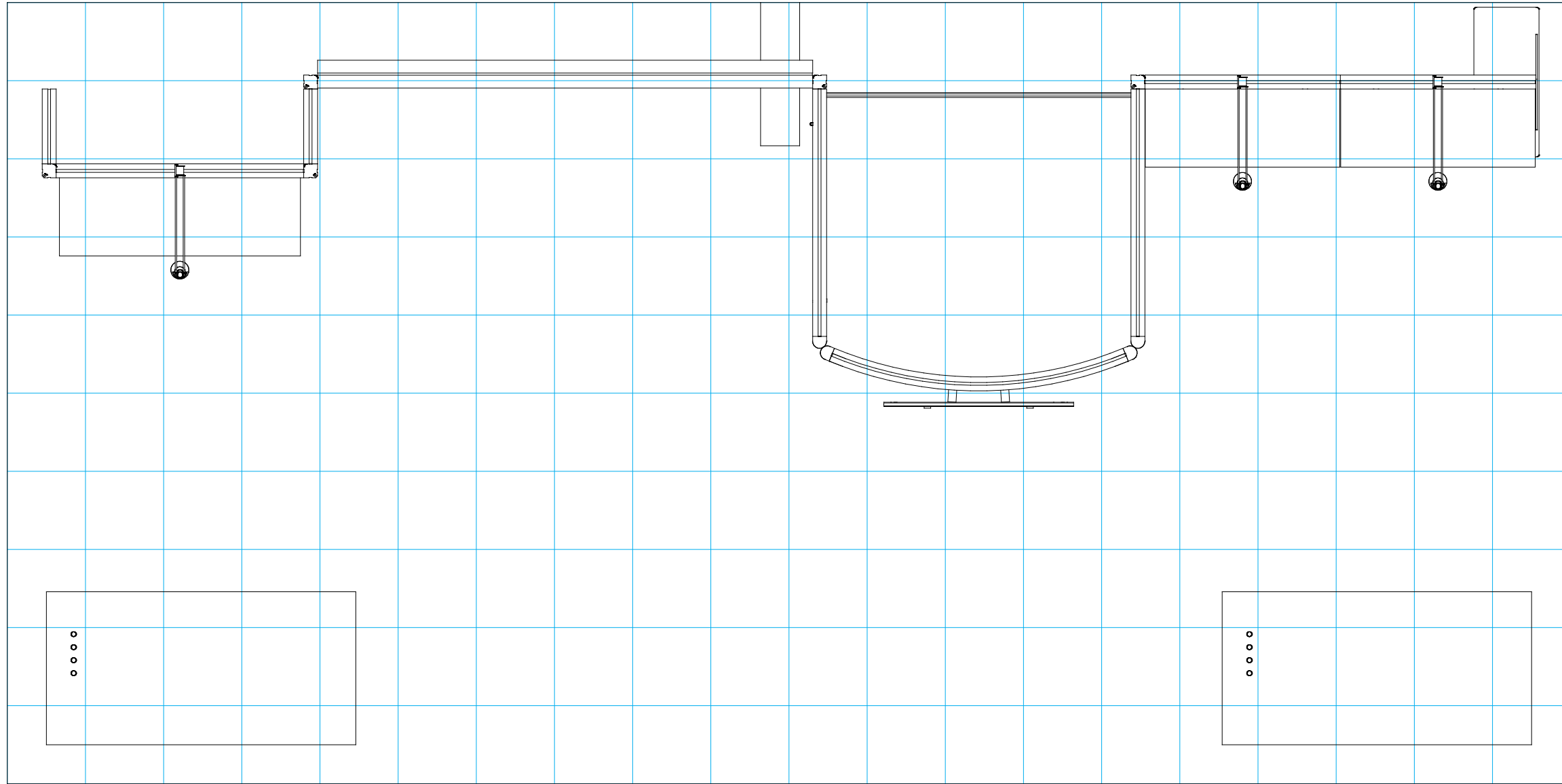

SETUP INSTRUCTIONS



 = 1 sq foot

General Setup Instructions

- Read entire setup instruction manual prior to unpacking parts and pieces.
- The setup instructions are created specifically for this configuration.
- Setup instructions are laid out sequentially in steps, including exploded views with detailed explanation for assembly.

Cleaning & Packing

- For Cleaning Metal, Plex, & Laminate Parts: Use a **MILD NON-ABRASIVE** cleanser and soft cloth/paper towel to clean all surfaces.
- Keep exhibit components away from heat and prolonged sun exposure. **Heat and UV exposure will warp and fade components.**
- Retain all provided Packing Materials. All provided packing materials are for ease of repacking & component protection.

Disassembly

- For loss prevention, tighten all set screws and locks during disassembly.

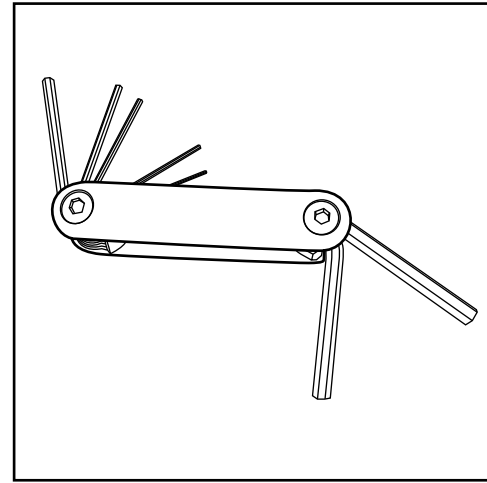

Hex Tool - Essential for Assembly

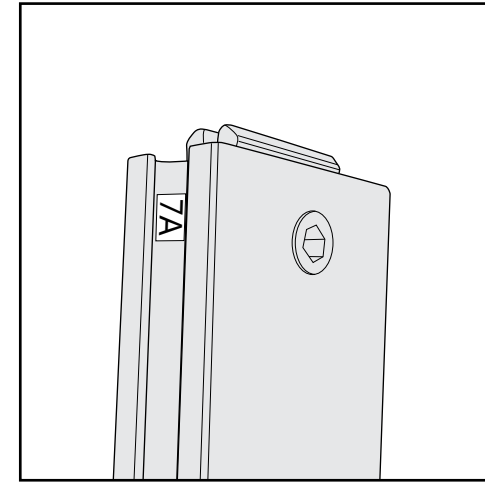

Part Identification - Numbering

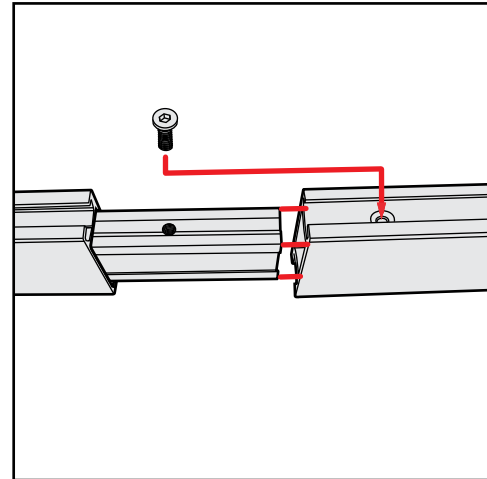

Spline Connection

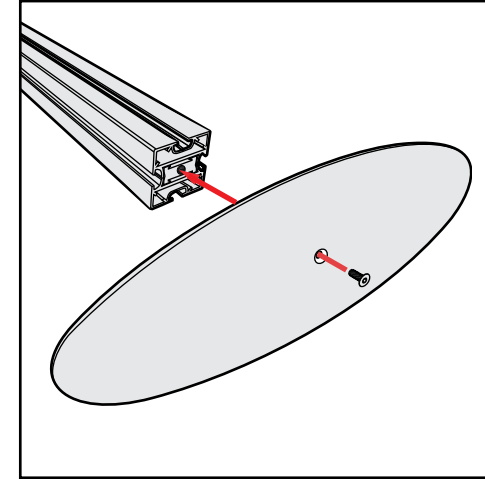

Base Plate & Extrusion Connection

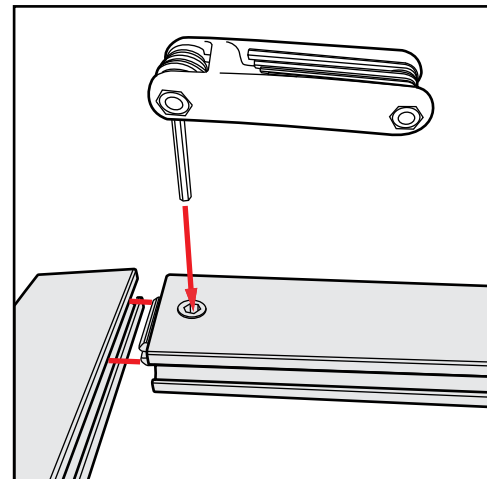

Extrusion & Lock Connection

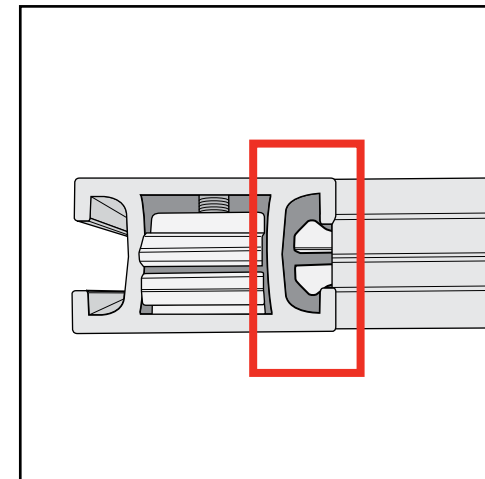

Engaged Lock



WARNING



DO NOT USE POWER TOOLS

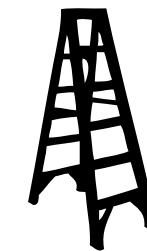

LADDERS OR LIFTS
MAY BE REQUIRED



ALL CONNECTIONS MUST
BE TIGHTLY SECURED

Side-by-Side Assembly

- 1) Frames: Place frames side-by-side with one higher than the other, then slide panel down to lock panels securely together.
- 2) Corner Connectors: Repeat Step 1 for installing corner connectors to frames.

Side-by-Side Disassembly

- 1) Pull pin lock outwards to disengage.
- 2) Pull frames upward and apart at the same time to detach.

Assembly

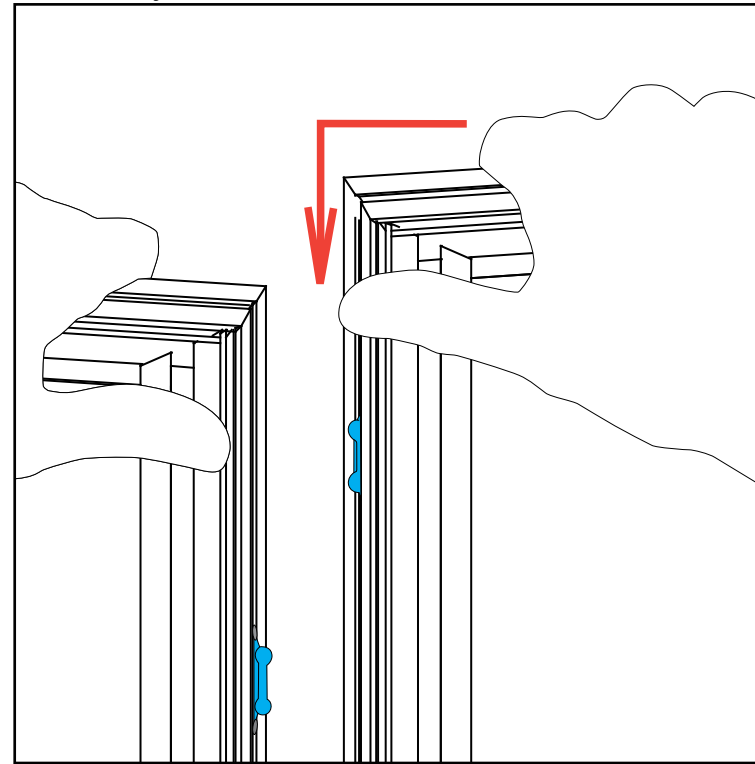

Assembly Cont'd

Push pin lock into hole of connecting frame.
Note: Block of pin lock will secure in groove.

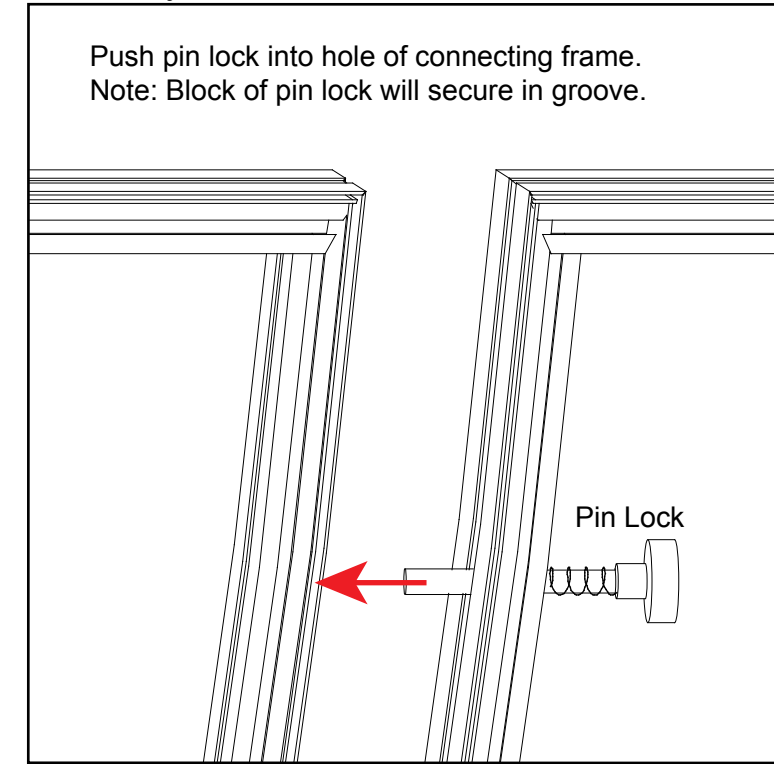

Corner Connector

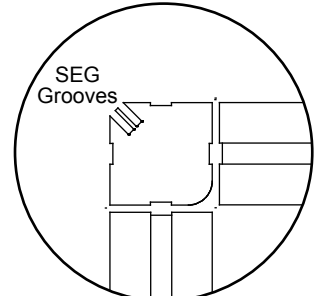

Top View
Note: Orientation of Corner Connector may change.

Stacking Assembly

- 1) Place one horizontal frame on top of the other, lining up the center grooves.
- 2) Turn stacking lock clockwise to tighten into place. Repeat for each lock.

Stacking Disassembly

- 1) Turn the stacking lock counter-clockwise to loosen.
- 2) The whole spring on the stacking lock should be in view to release each frame. The disengaged spring should release the stacking lock. If not, keep turning the stacking lock until it disengages.

Stacking

Push stacking lock into the slot of the upper frame, then spin the cap to tighten the lock.

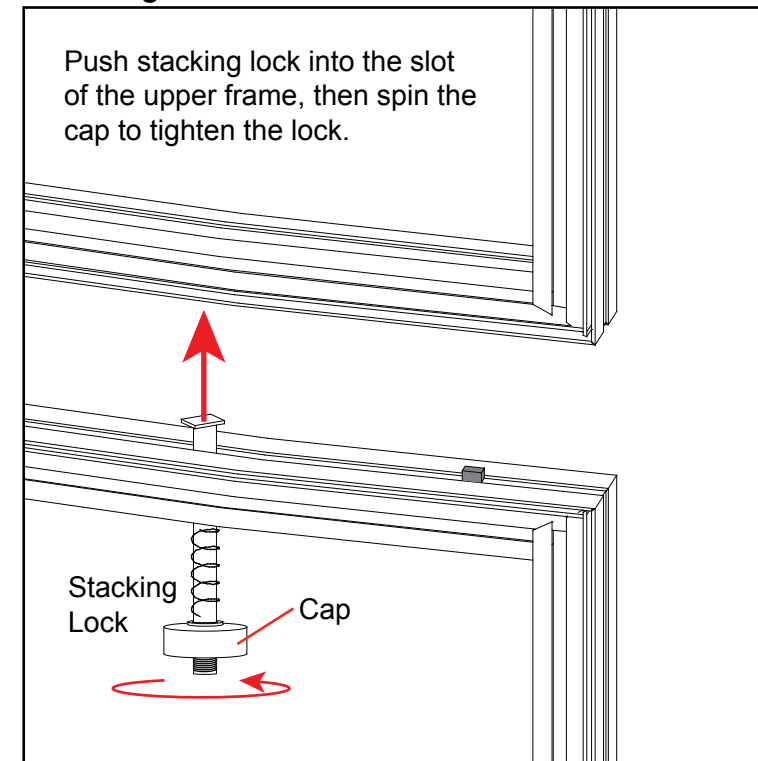

Unstacking

Disengage the stacking lock by spinning the cap counter clockwise and pulling down.

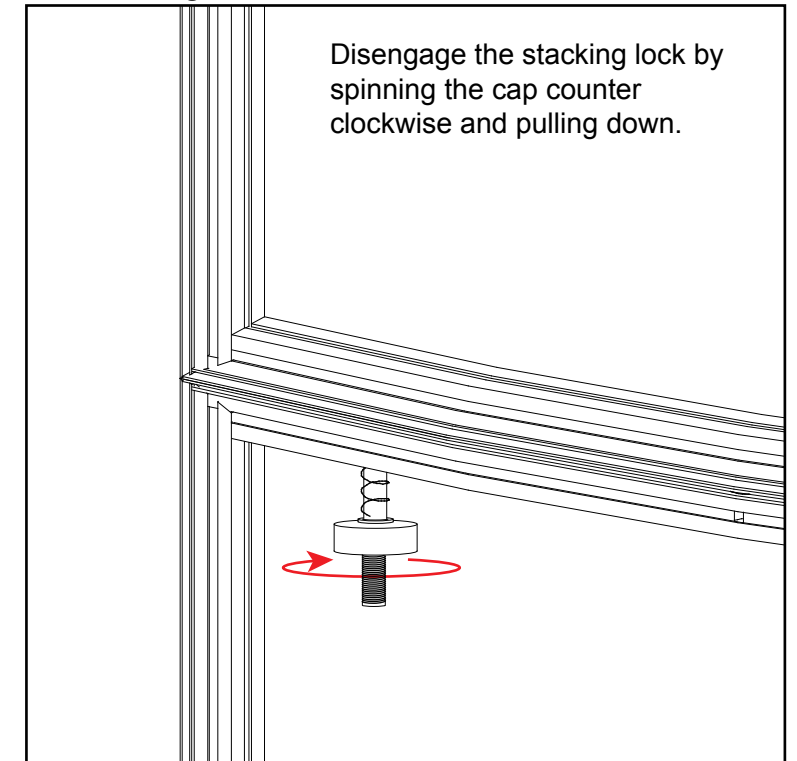

Straight Connection

When assembling frame, first attach all **straight connectors**, then attach **corner connectors**.

- 1) Place extrusions end-to-end.
- 2) Loosen all knobs, then slide **straight connectors** across the seam of extrusions.
- 3) Tighten all knobs to secure connection.

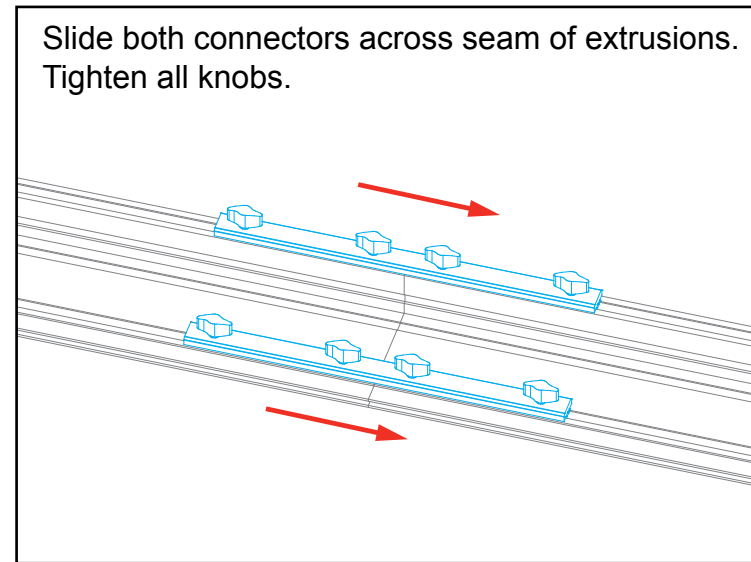
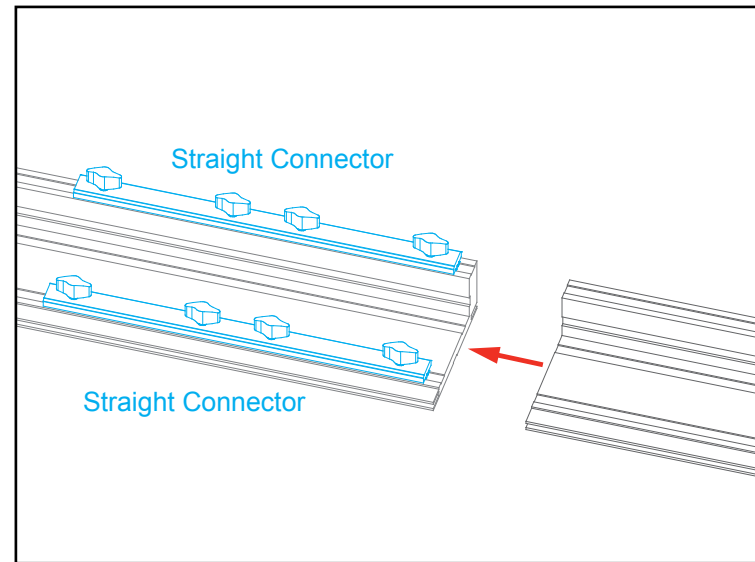

All knobs must be tightened securely to ensure a proper connection.

Disassembly

- 1) Loosen all knobs.
- 2) Slide connectors off of one extrusion.
- 3) Tighten knobs to prevent loss during packing & shipping.

Keep straight connectors in groove of extrusion. Do not remove connectors during disassembly.

Corner Connection

- 1) Loosen knobs, then slide vertical extrusions onto **corner connectors** of **lower** horizontal extrusion.
- 2) Slide **corner connectors** of **upper** horizontal extrusion into grooves of vertical extrusions.
- 3) Tighten all knobs to secure connection.

Disassembly

- 1) Loosen knobs on vertical extrusions.
- 2) Slide the vertical extrusions off of **corner connectors** on lower and upper horizontal extrusions.

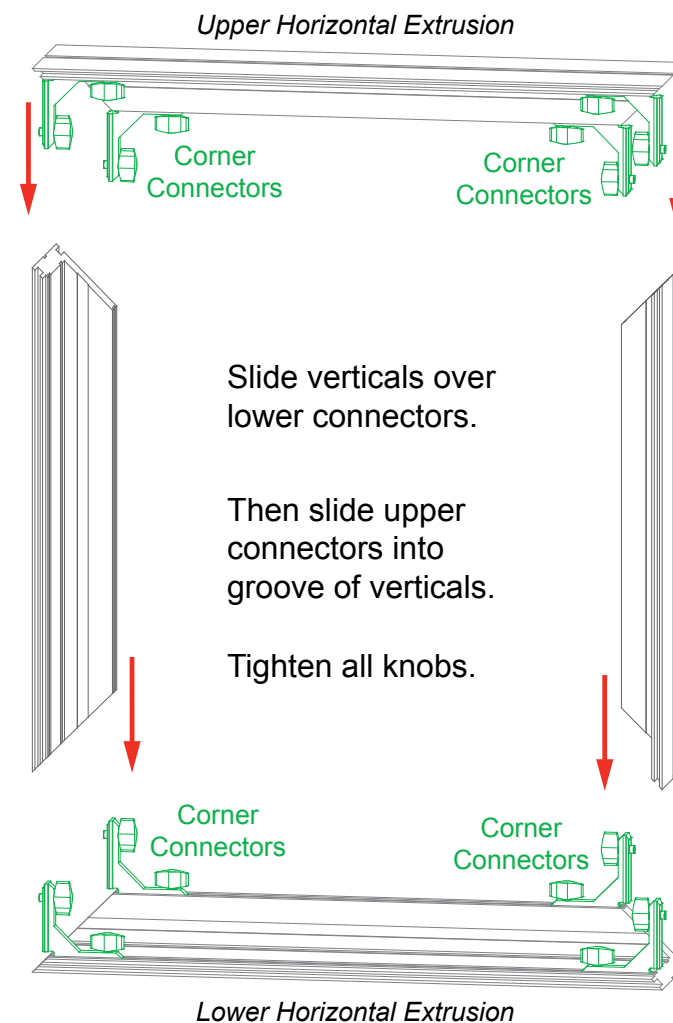

Adjust connectors if necessary to prevent gaps in connection.

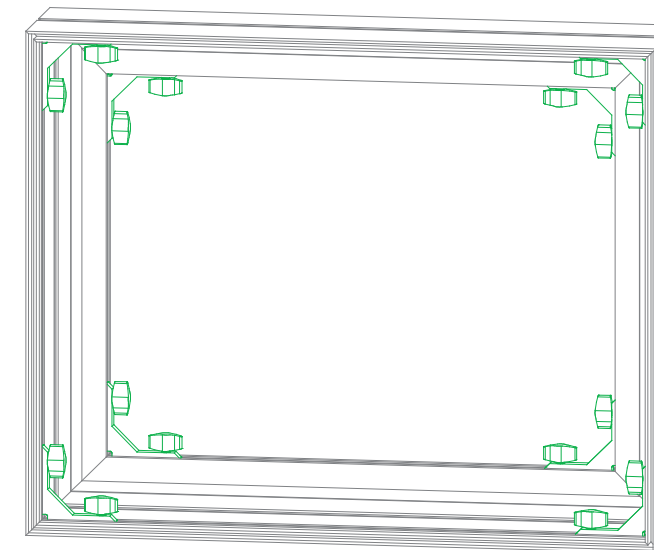

COMPLETED ASSEMBLY

All knobs must be tightened securely to ensure a proper connection.

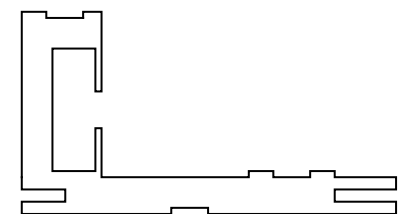

CEI110 Profile

SEG Graphic Installation *in 3 Steps*

The Perfect Fit

STEP 1: Attach Corners

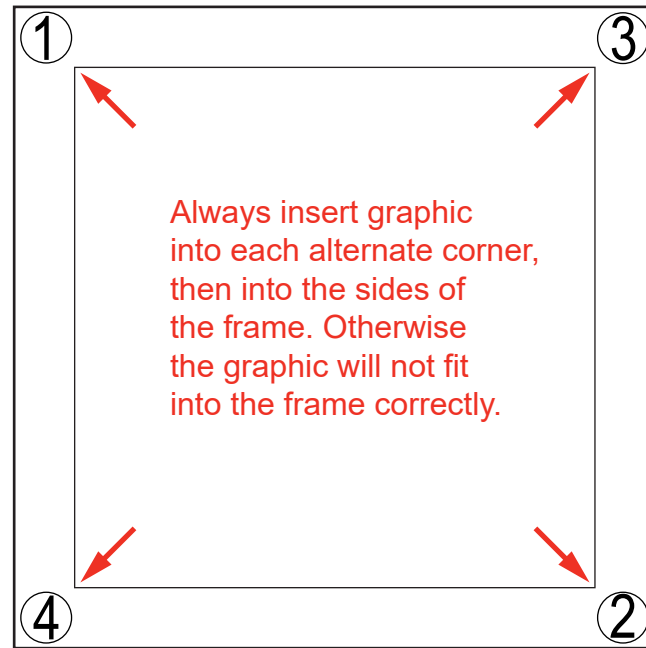

STEP 2: Attach Middle

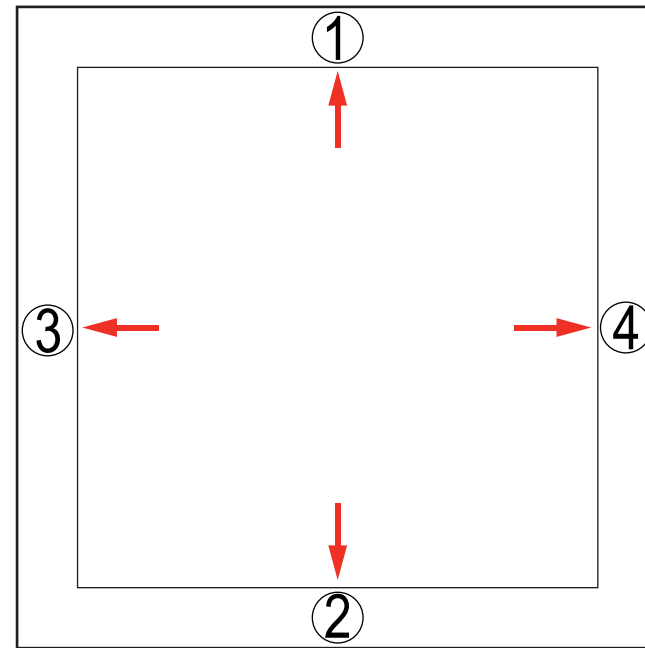

STEP 3: Attach Sides

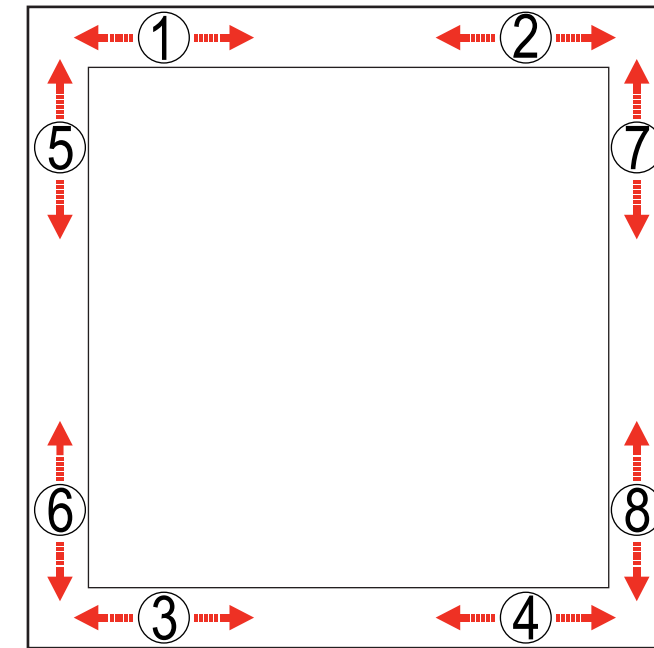

Insert narrow side of silicone welt into the channel at corner 1, with fabric to the outside.

Repeat for opposite corner 2, then corner 3, then corner 4.

Once corners are attached, press the middle of edge 1 into the channel. Then press middle of edge 2 into the channel on opposite side.

Repeat with edge 3 & 4.

Once the middle of sides are attached, fully press the silicone welt into the channel, between center and corner at location 1. Repeat the process between center and corner at location 2.

Do the same for welt on opposite side, at locations 3 & 4. Then repeat for locations 5 & 6 and 7 & 8.

Once the welt is fully inserted on all sides, smooth out edges as needed for a perfect fit.



To remove the graphic from the frame, locate the fabric **pull tab**. Gently pull on the tab to remove the graphic.

Install video:



CRATE PACKING

Item	Qty.	Description
1	1	76" CEI110 Horizontal Extrusion
2	1	76" CEI110 Horizontal Extrusion
3	1	95" CEI110 Vertical Extrusion
4	1	95" CEI110 Vertical Extrusion

Steps:

- 1) Assemble extrusions flat on floor.
See CEI152 Frame Assembly sheet.
- 2) Connect light cords and attach transformers.

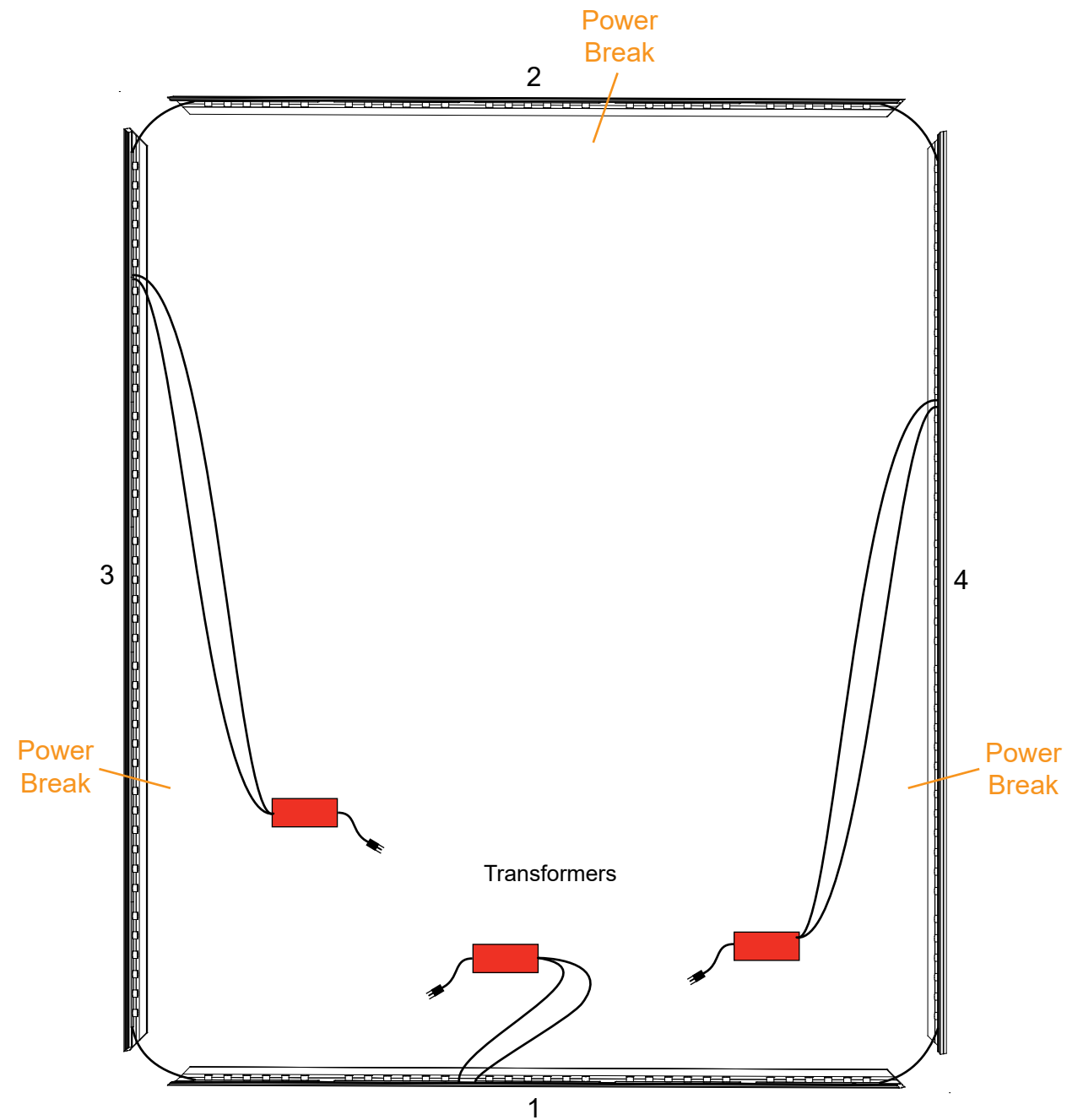
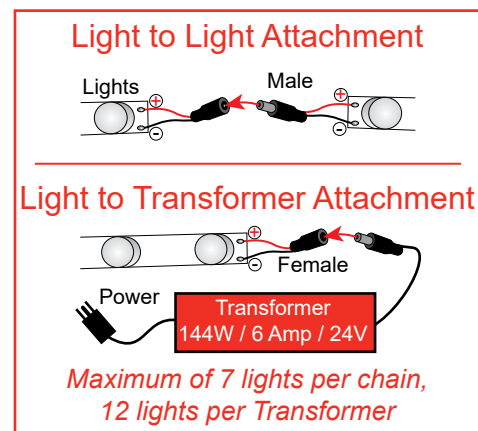

FRONT ELEVATION VIEW

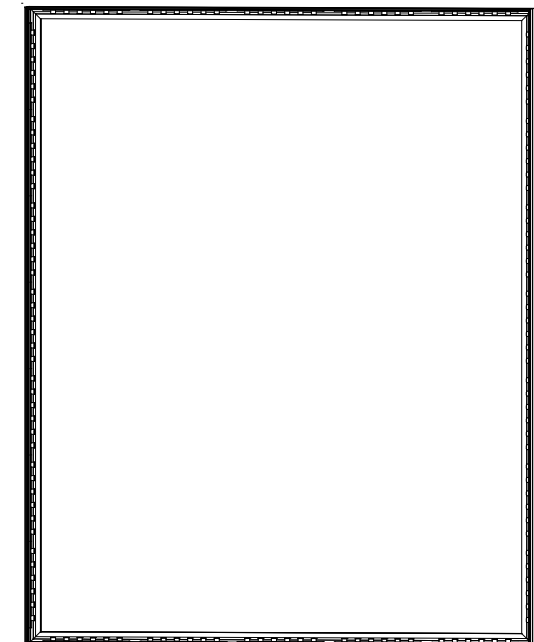

Completed Assembly

Assemble frame flat on ground.

Item	Qty.	Description
5,5A	1,1	Base Plate
6	2	47.307" Z45 Horizontal Extrusion
1	1	11.5"w x 95"h Gravitee Panel
2	1	94.5" Gravitee Corner Connector w/ Caps
3	1	38"w x 95"h Gravitee Panel w/ (2) 91.904" S44
4	1	94.5" Gravitee Corner Connector w/ Caps
5	1	11.5"w x 95"h Gravitee Panel
6	1	95" Gravitee Corner Connector
7	1	95" Gravitee Corner Connector
8	1	95" Gravitee Corner Connector
9	1	30"w x 95"h Gravitee Panel w/ (2) 91.904" S44
10	1	30"w x 95"h Gravitee Panel w/ (2) 91.904" S44
11	1	38"w x 95"h Gravitee Panel w/ Door
12	1	95" Gravitee Hinged Corner Connector
13	1	47.123"w x 95"h Gravitee Curved Panel w/ (2) 91.904" S44
14	1	95" Gravitee Hinged Corner Connector
15	1	94.5"h Gravitee Corner Connector

Steps:

- 1) Attach base plate [5] to horizontal [1], using bolts, washers, and wing nuts.
- 2) Attach base plate [5A] to panel [10]. See **Base Plate** detail.
- 3) Assemble panels & connectors in numerical order, as shown. See Gravitee Assembly Instruction sheet for details.
- 4) Attach horizontals [6] between connectors [7] and [8], as shown.
- 5) Attach assembled lightbox between connectors [6] and [7]. See **Lightbox Attachment** detail.
- 6) Install SEG graphic to assembled panels. See General Information sheet for **SEG Graphic Installation** instruction.

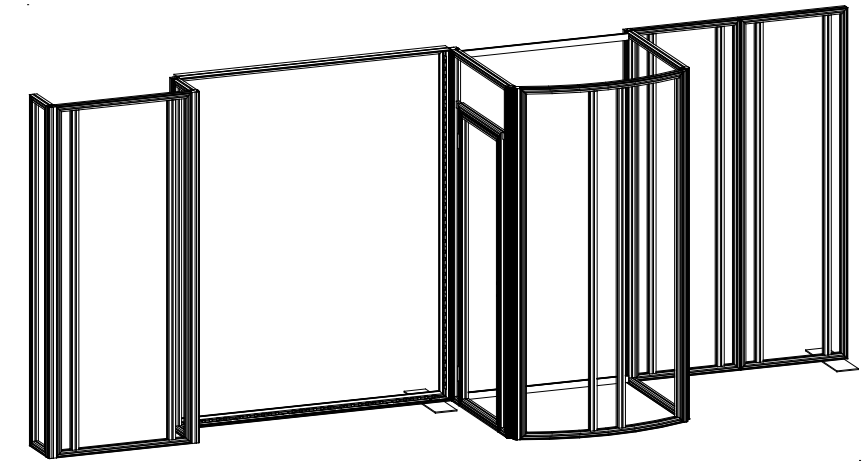

Completed Assembly

Keep S44 verticals attached to Gravitee panels [3] [13] [9] and [10].

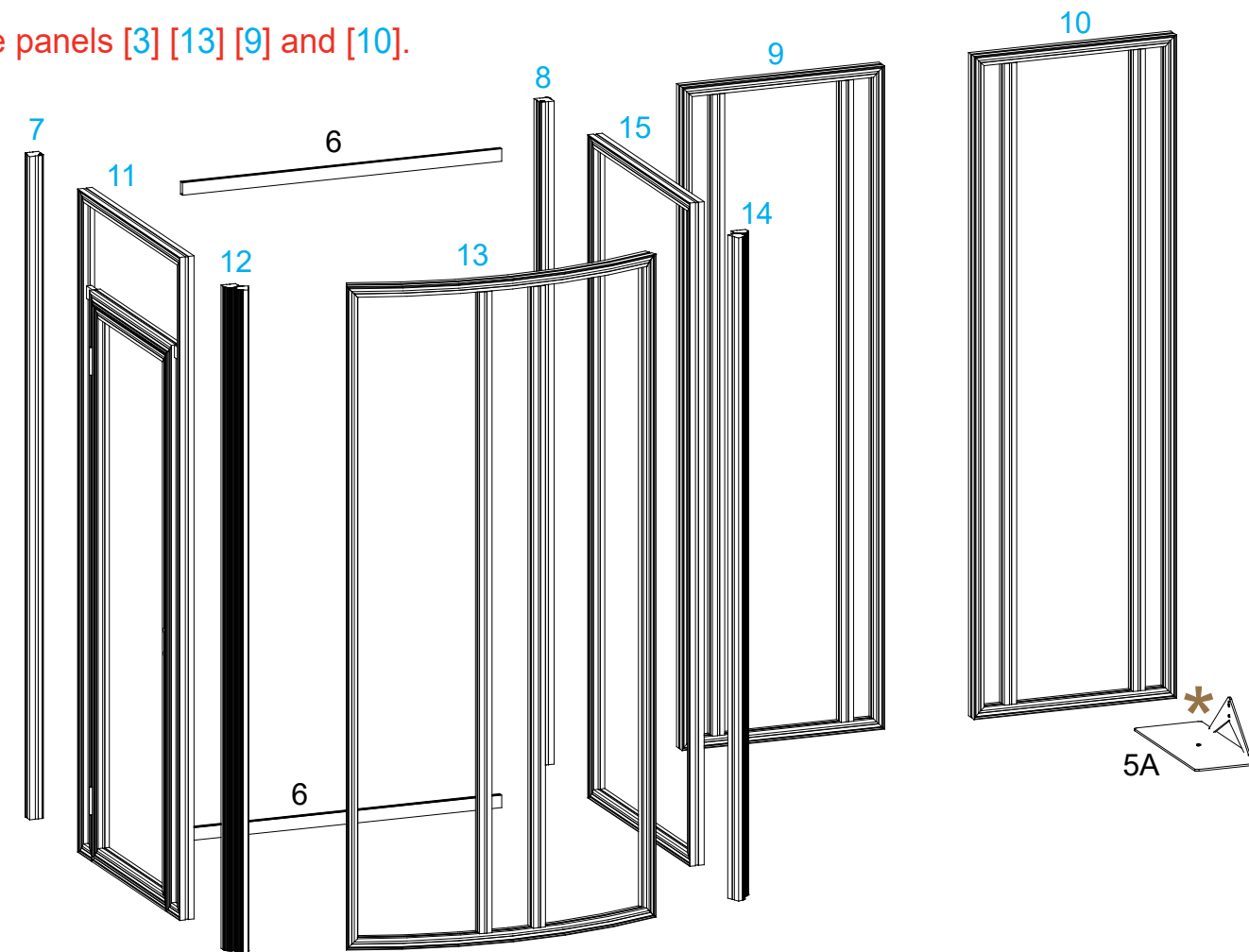
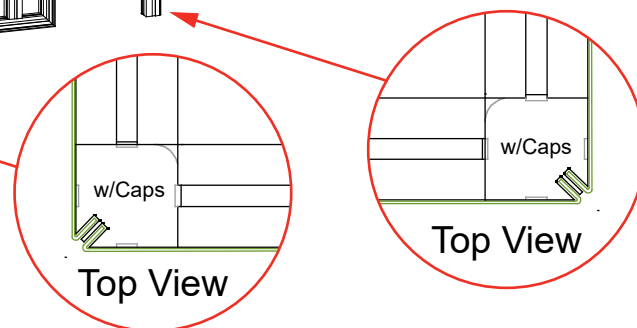
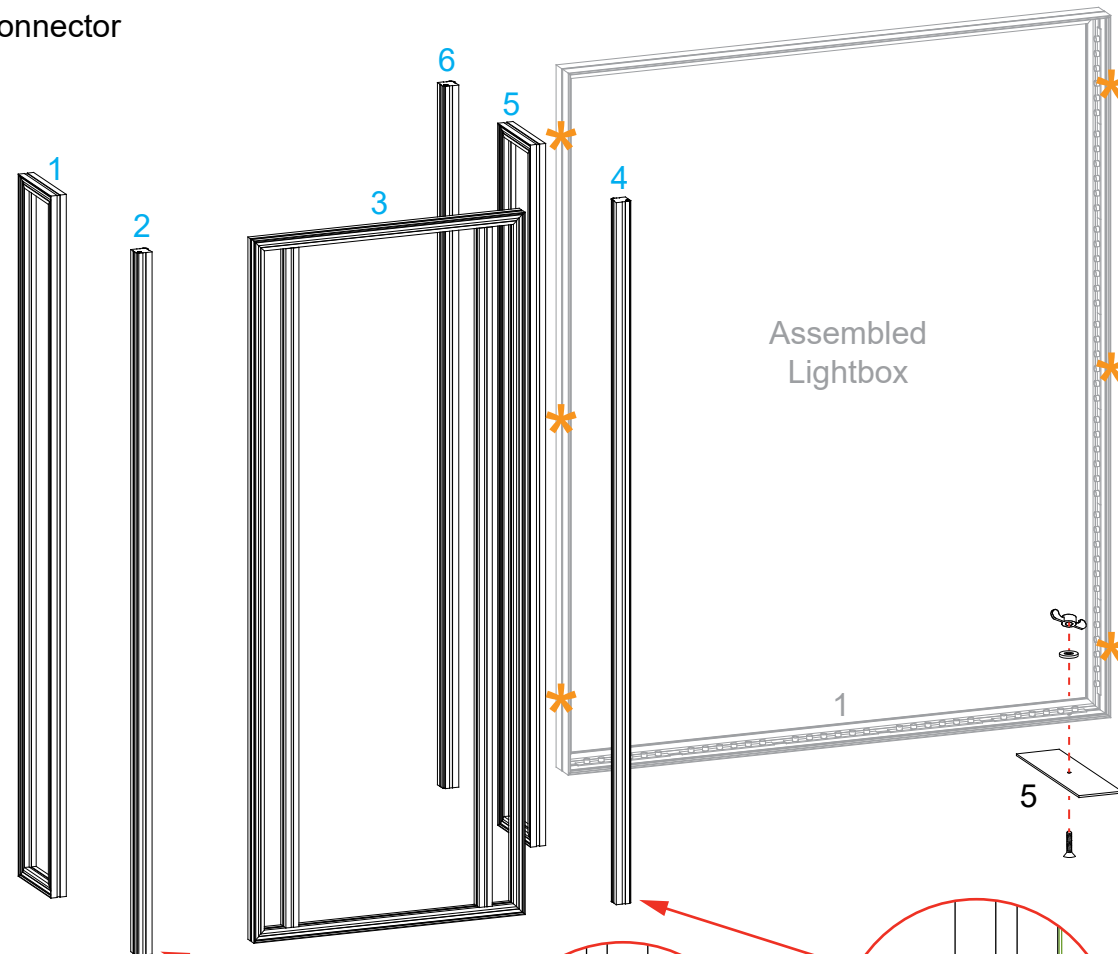
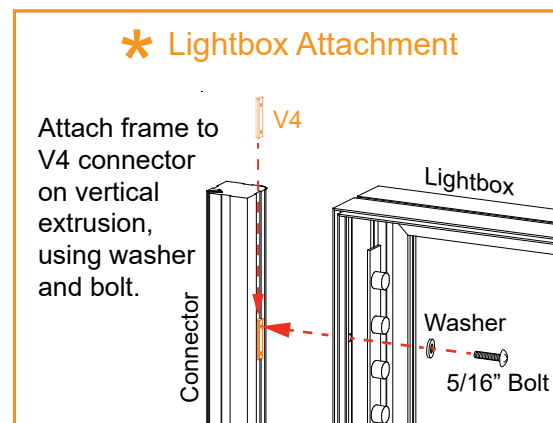
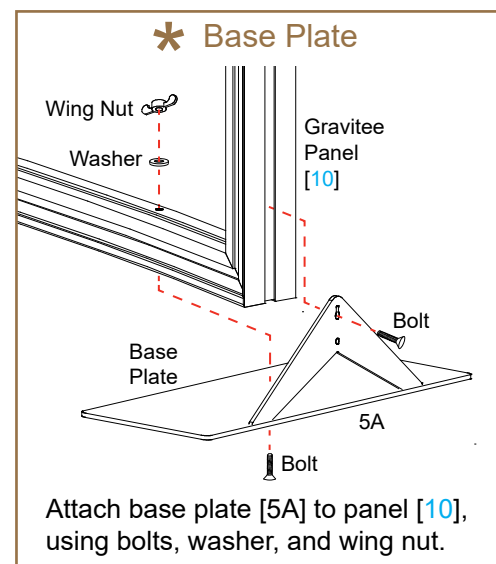

Steps:

- 1) Connect lights to top of panels [3] [9] and [10]. See **Light Connection** detail.
- 2) Attach shelves to panels [3] [9] and [10]. See **Shelf Attachment** detail.
- 3) Attach monitor mount to panel [13]. See **Monitor Mount Attachment** detail.

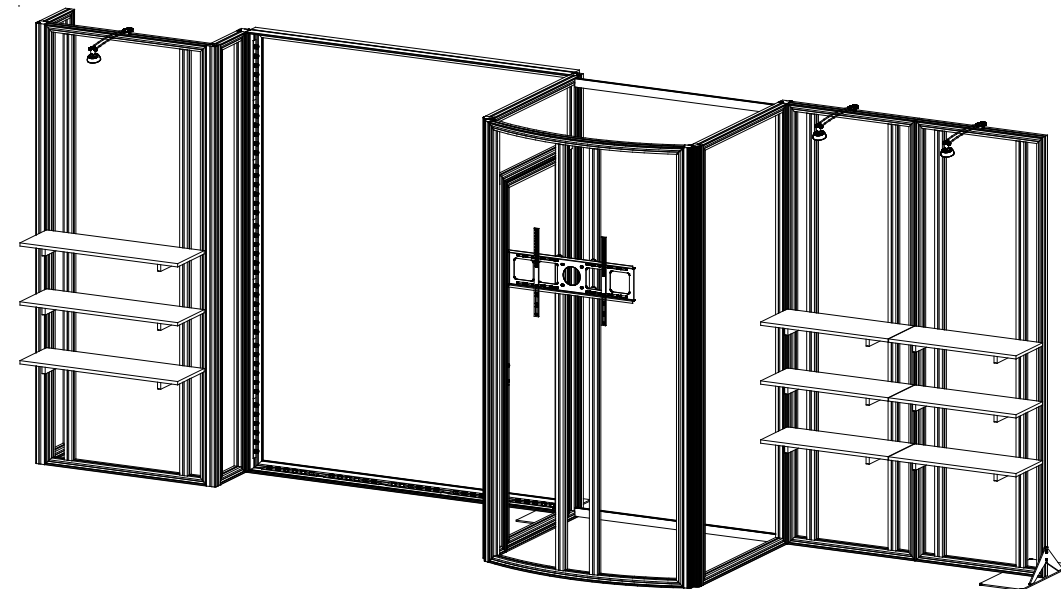
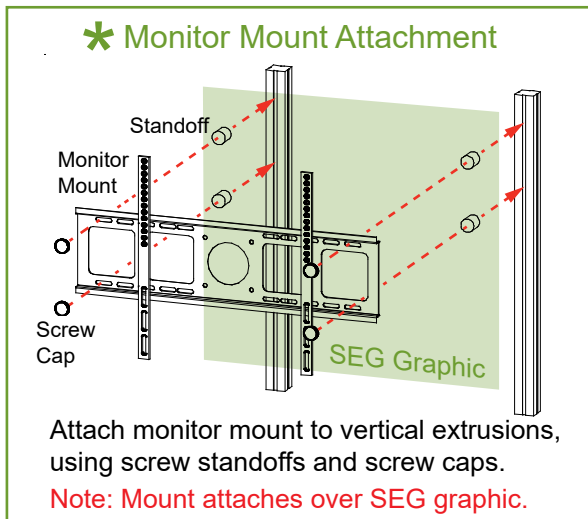

Completed Assembly

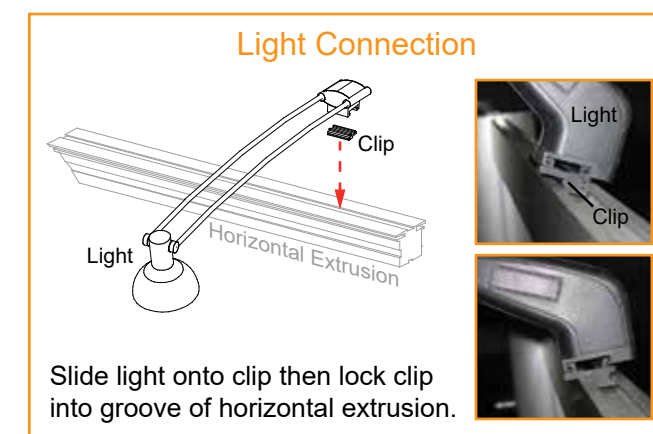
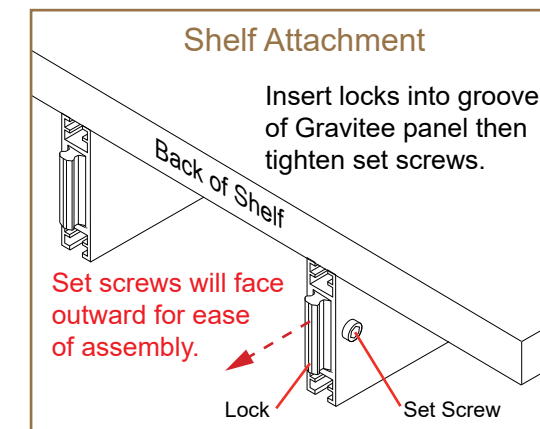
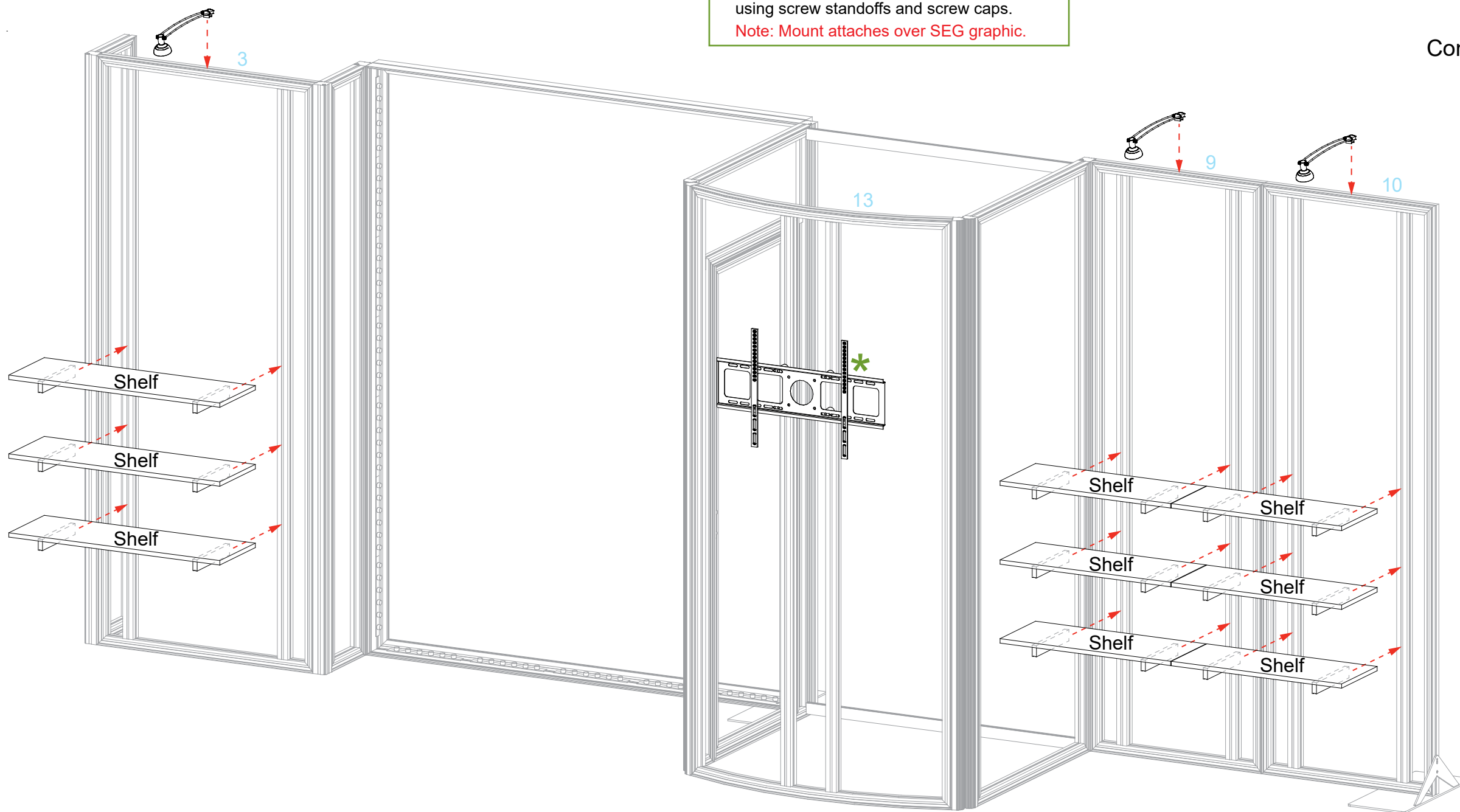

Item	Qty.	Description
1,1A	1,1	46.25" CEI110 Horizontal Extrusion
2,2A	1,1	37.5" CEI110 Vertical Extrusion
3,3A	1,1	37.5" S44 Vertical Extrusion
4	1	37.5" S44 Vertical Extrusion w/ Door Hinges
5	1	37.5" S44 Vertical Extrusion w/ Door Stops
6	1	37.5" S44 Vertical Extrusion w/ Door Hinges
7,7A	2,2	14.153" Z45 Horizontal Extrusion
8,8A	2,2	20.408" Z45 Horizontal Extrusion

Steps:

- 1) Assemble CEI110 extrusions [1,1A,2,2A], inserting 2-piece Sintra light blocker. See CEI110 Frame Assembly sheet for instruction.
- 2) Connect lights and transformer. See [Light Connection](#) details.
- 3) Attach horizontals [7] and [8] between verticals [3,4,5,6,3A].
- 4) Slide infills between verticals [3,4] and [3A,6], making sure Velcro is facing inward.
- 5) Connect doors to verticals [4] and [6]. See [Door Connection](#) detail.
- 6) Attach horizontals [7A] and [8A] between verticals [3,4,5,6,3A].
- 7) Connect shelf supports to Velcro on infills.

Keep counter sides assembled, when packing.

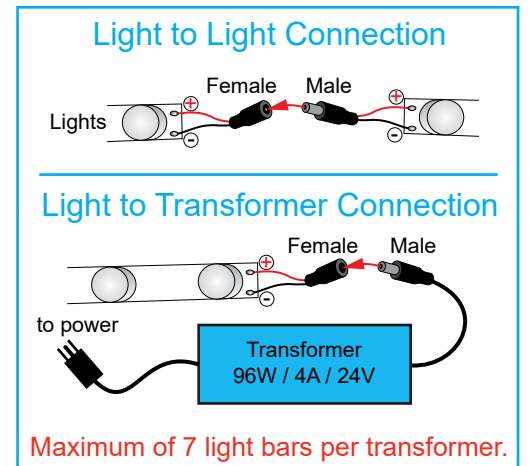
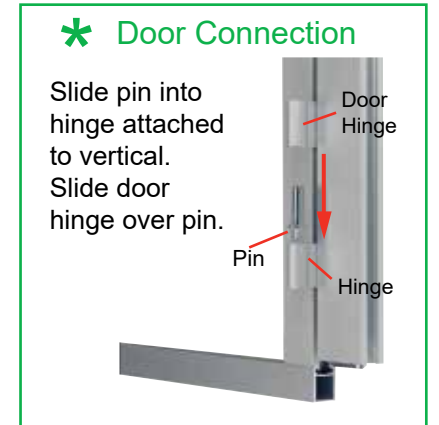
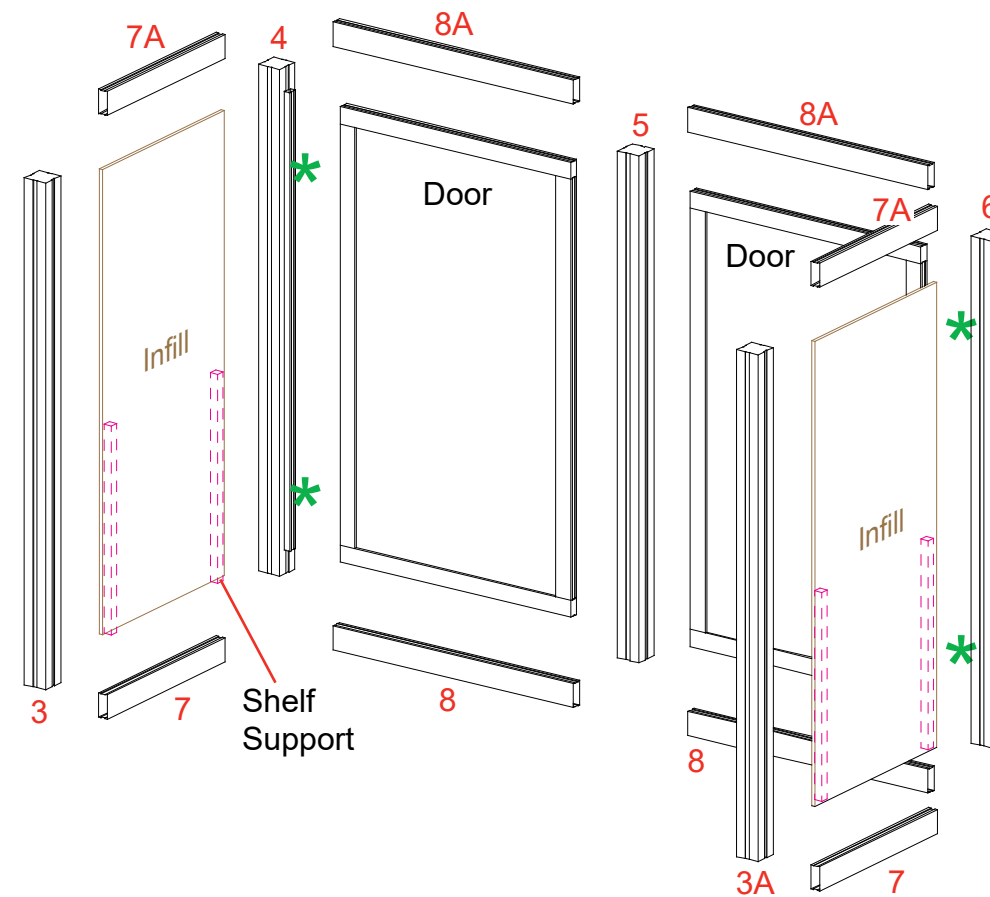
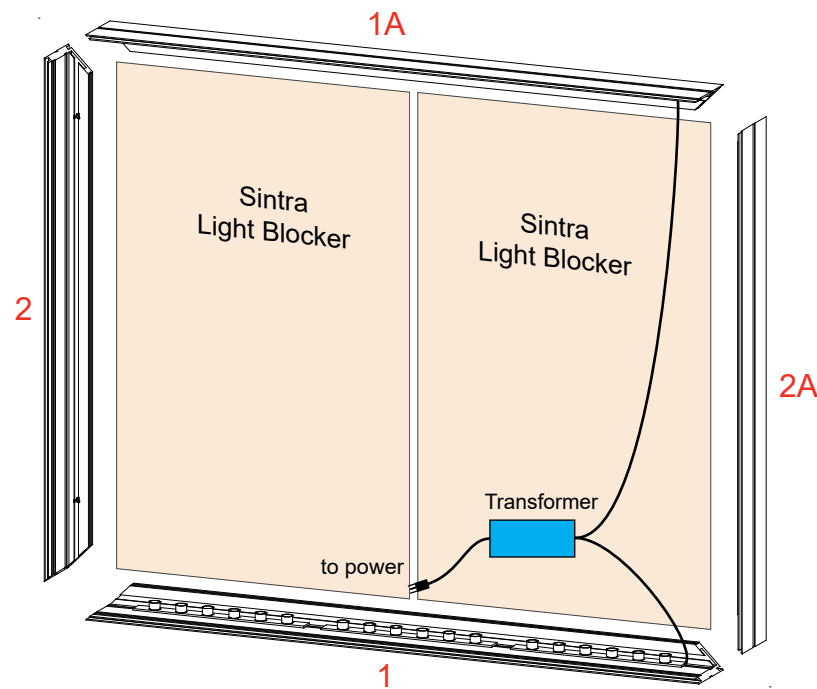

Steps:

- 1) Attach assembled frame to verticals [3] and [3A].
See [Frame Attachment](#) detail.
- 2) Install SEG graphic to front of assembled frame.
See [SEG Graphic Installation](#) detail.
- 3) Place shelf inside assembled base on top of pins and supports.
- 4) Place counter top on assembled base, then secure with pins.
See [Counter Top Attachment](#) detail.

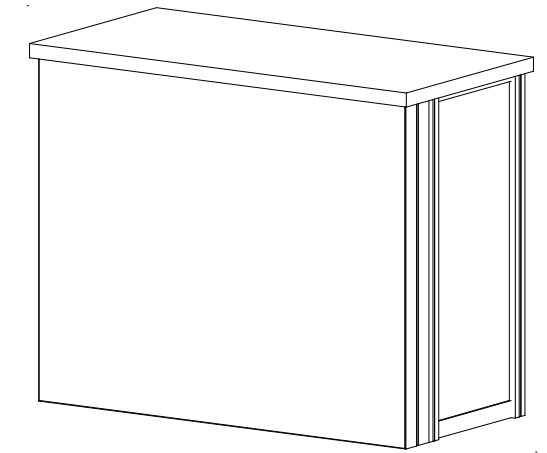
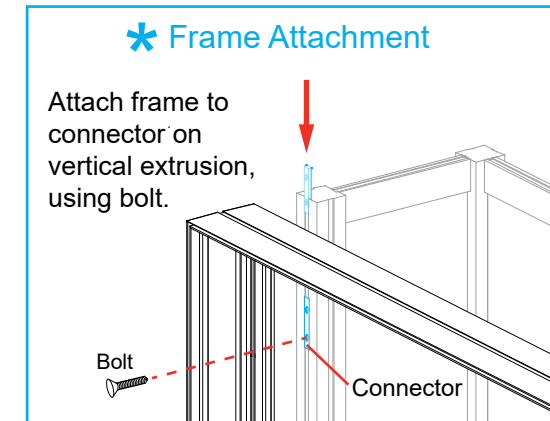
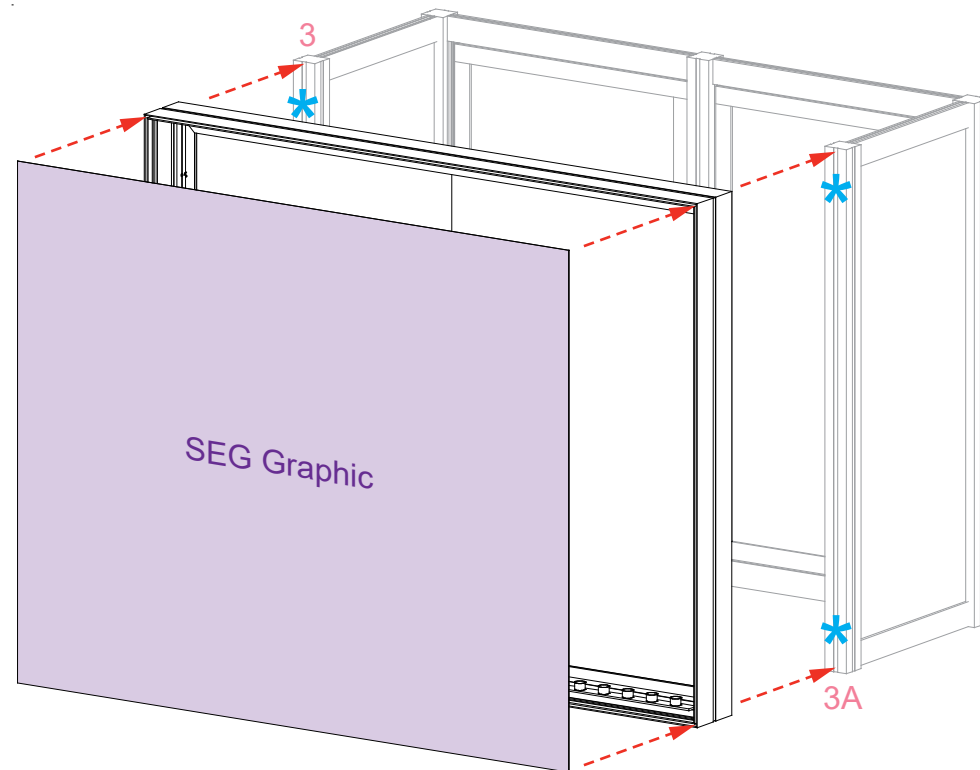

Completed Assembly

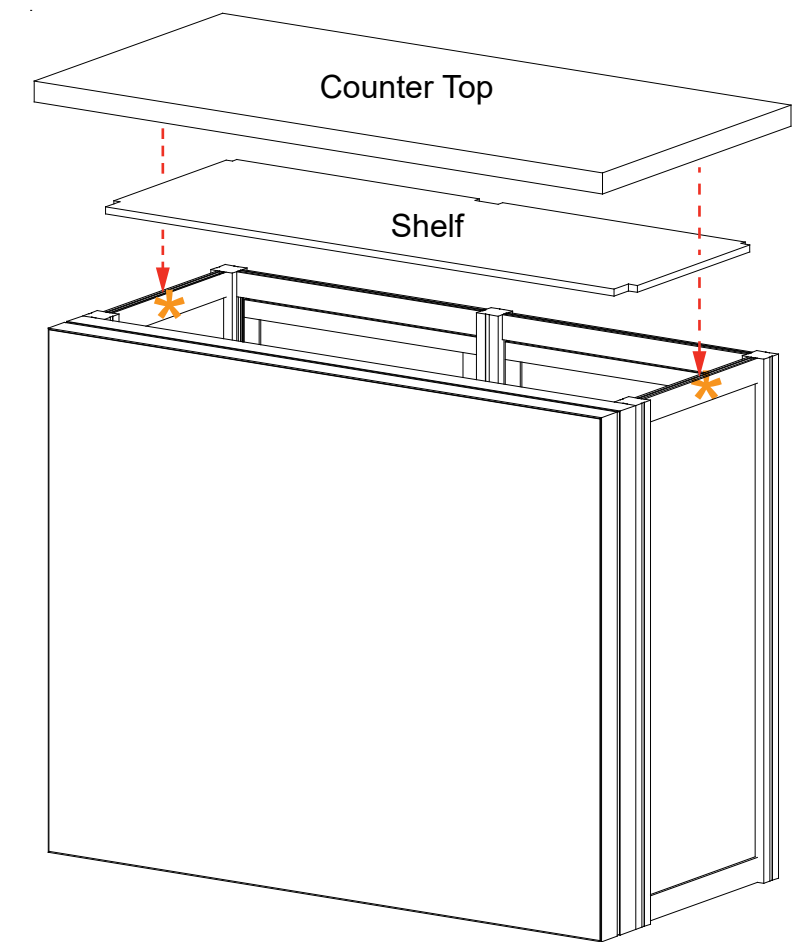

SEG Graphic Installation

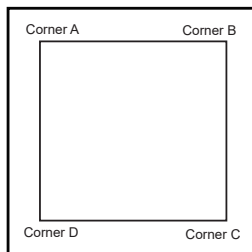

It is important to first insert graphic into each alternate corner then to the sides of the frame. If this is not done, graphic will not fit into the frame correctly.



Step 1
Insert corner A. Turn edge of graphic so silicon welt is perpendicular to face of graphic. Insert narrow side of welt with fabric to outside into the channel. Repeat for other side of this corner.



Step 2
Repeat Step 1 for opposite corner C, then insert corner D, to complete the installation of the corners.



Step 3
Once all corners are inserted, press one silicon edge into channel from corners and work toward the center. Make sure welt is fully inserted into channel. Continue until all sides are done. Smooth out edges of graphic.



Graphic Removal

To remove the graphic from the frame, locate the fabric pull tab. Gently pull up on the tab to remove the fabric.

