

- Steps:
- 1) Install Base Plate to bottom of Kiosk, using bolts.
 - 2) Attach Sintra Graphic to Kiosk, using screw caps.
 - 3) Connect Shelf, using bolts from back side of Kiosk.
 - 4) Attach iPad clamshell to top of Kiosk, as shown in detail.
 - 5) Connect power cords to RGB LED lights on sides of Kiosk.
See opposite page for RGB Remote Controller instructions.

*** iPad Clamshell Attachment**

- 1) Attach Connector Plate & Spacer to top of kiosk using bolt to t-nut connection.
- 2) Connect iPad clamshell to connector plate with hex nuts.

***** Connector Plate & Spacer stay attached to Kiosk. *****

*** RGB LED Power Cord Attachment**

Connect transformer to RGB LED Controller. Then connect transformer to power source.

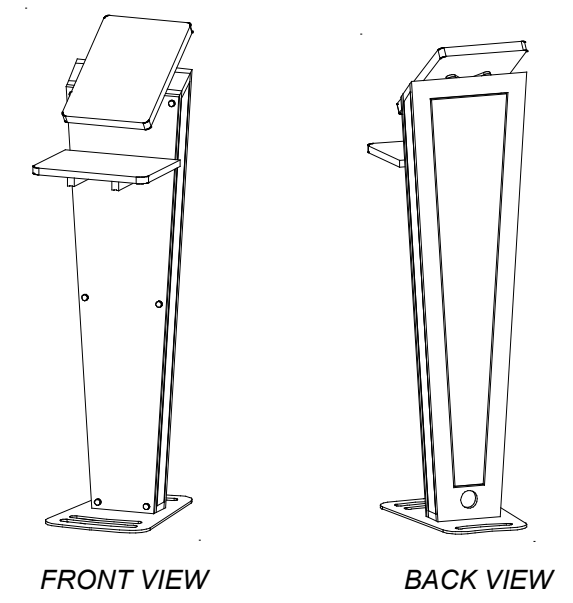

Completed Assembly

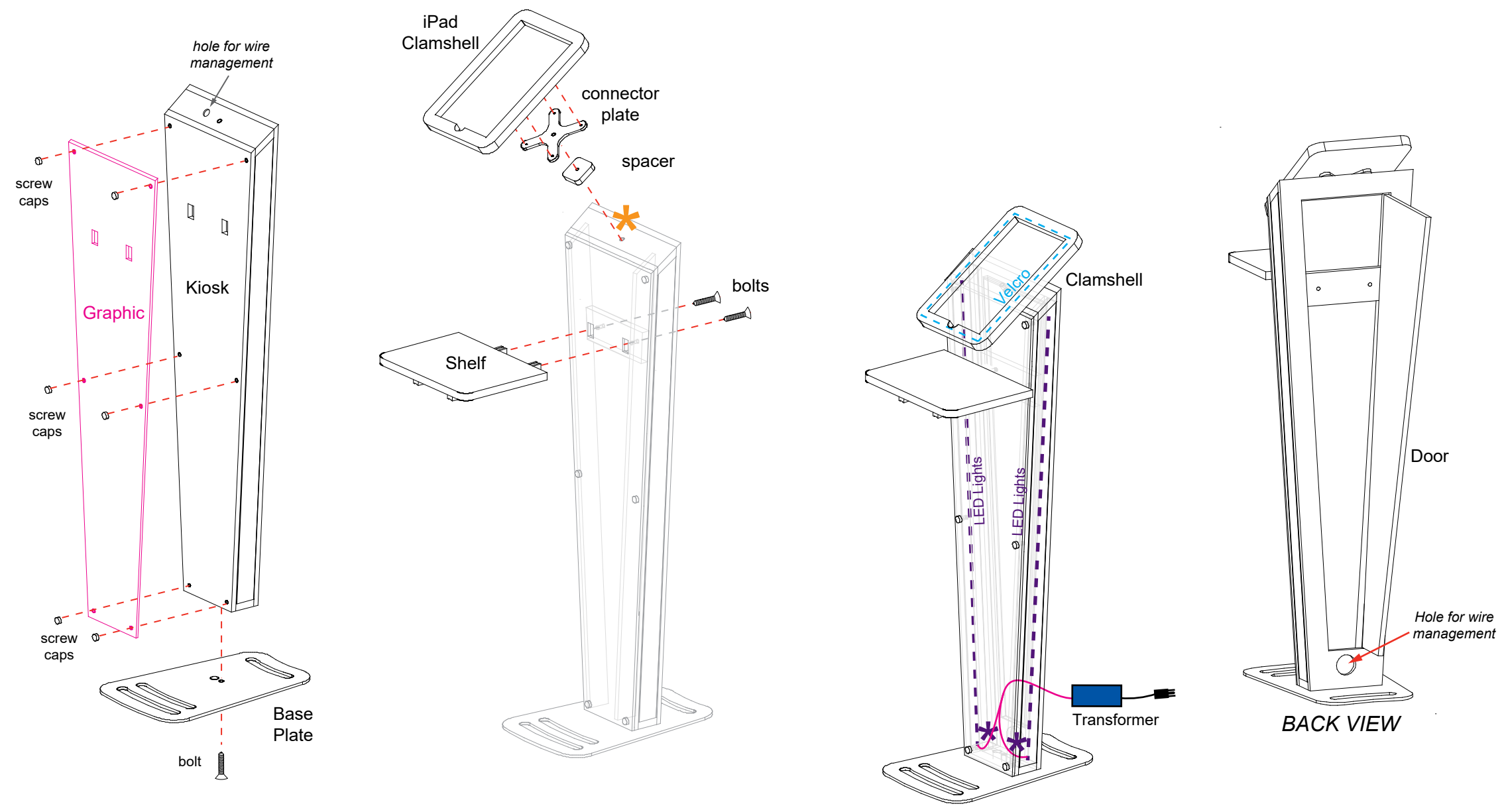

Cord Management for iPad

Feed iPad cord through top hole of post, then out bottom hole of post. Connect to power.

Optional Cover for Home Button

- 1) Remove foam lining from inside bottom of clamshell.
- 2) Attach Home Button Shield with double-sided tape to inside of clamshell, keeping top of shield flush with clamshell opening.

NOTE: This is a permanent fix and can't be easily removed.

SETUP INSTRUCTIONS

General Setup Instructions

- Read entire setup instruction manual prior to unpacking parts and pieces.
- The setup instructions are created specifically for this configuration.
- Setup instructions are laid out sequentially in steps, including exploded views with detailed explanation for assembly.

Cleaning & Packing

- For Cleaning Metal, Plex, & Laminate Parts: Use a **MILD NON-ABRASIVE** cleanser and soft cloth/paper towel to clean all surfaces.
- Keep exhibit components away from heat and prolonged sun exposure. **Heat and UV exposure will warp and fade components.**
- Retain all provided Packing Materials. All provided packing materials are for ease of repacking & component protection.

Disassembly

- For loss prevention, tighten all set screws and locks during disassembly.

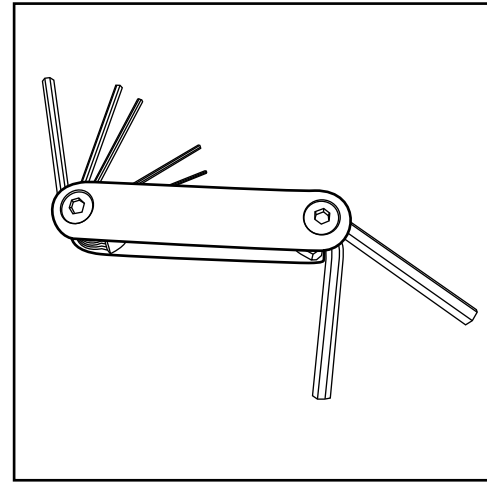

Hex Tool - Essential for Assembly

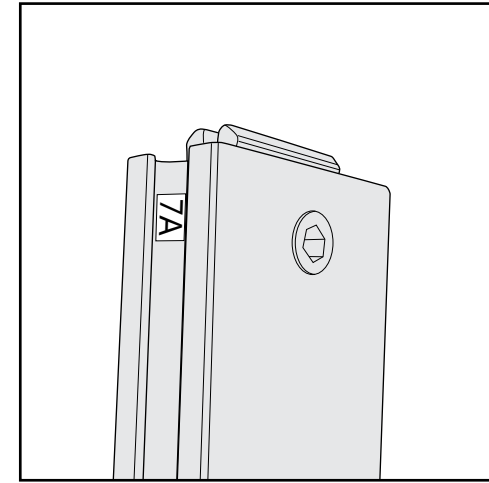

Part Identification - Numbering

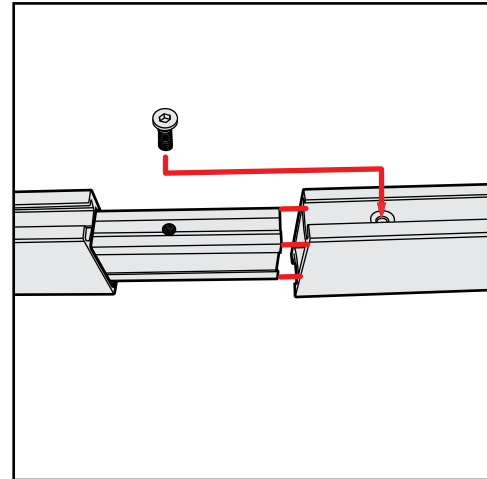

Spline Connection

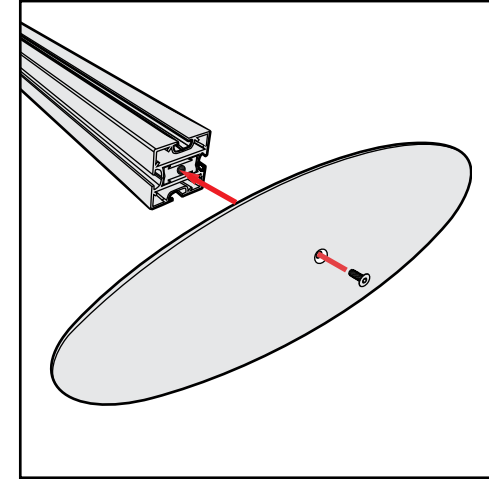

Base Plate & Extrusion Connection

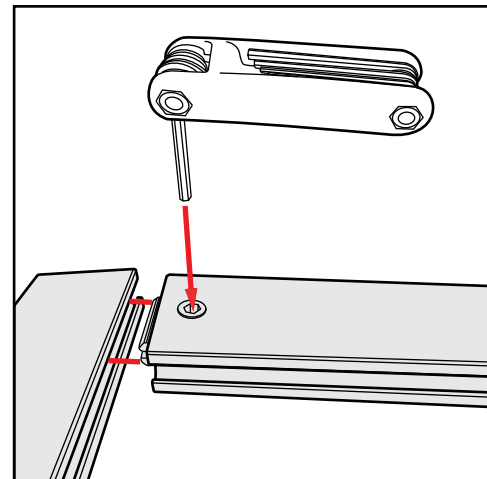

Extrusion & Lock Connection

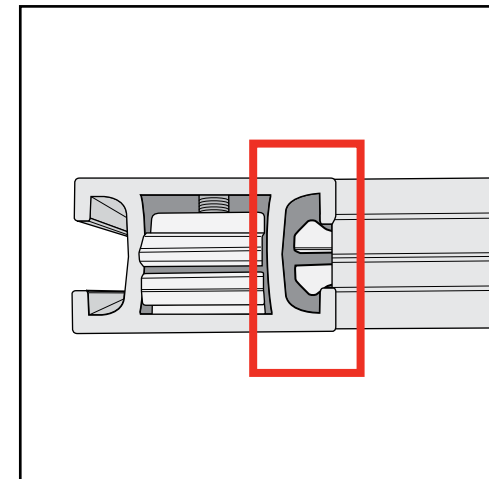

Engaged Lock



WARNING



DO NOT USE POWER TOOLS

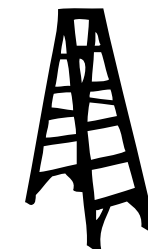

LADDERS OR LIFTS
MAY BE REQUIRED



ALL CONNECTIONS MUST
BE TIGHTLY SECURED