

Item	Qty.	Description
1	1	24" diameter Base
2	1	70"h Q914 Vertical Extrusion w/ brackets
3	1	30" diameter Counter w/ chargers

**Steps:**

- 1) Attach Base to bottom of vertical [2], using bolt.
- 2) Place Counter [3] onto vertical [2] & secure to brackets using bolts.
- 3) Attach Monitor Mounts to vertical [2].  
See **Monitor Mount Attachment** detail.
- 4) Run power cords to wireless chargers & monitor through wire management holes to power source.

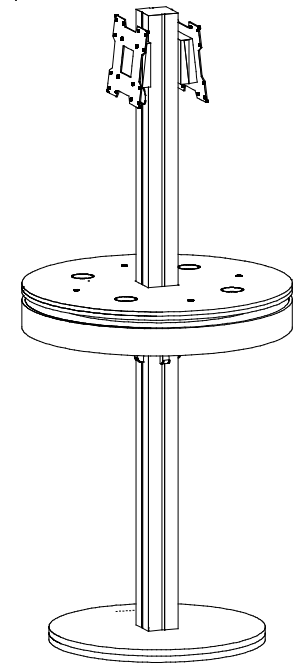
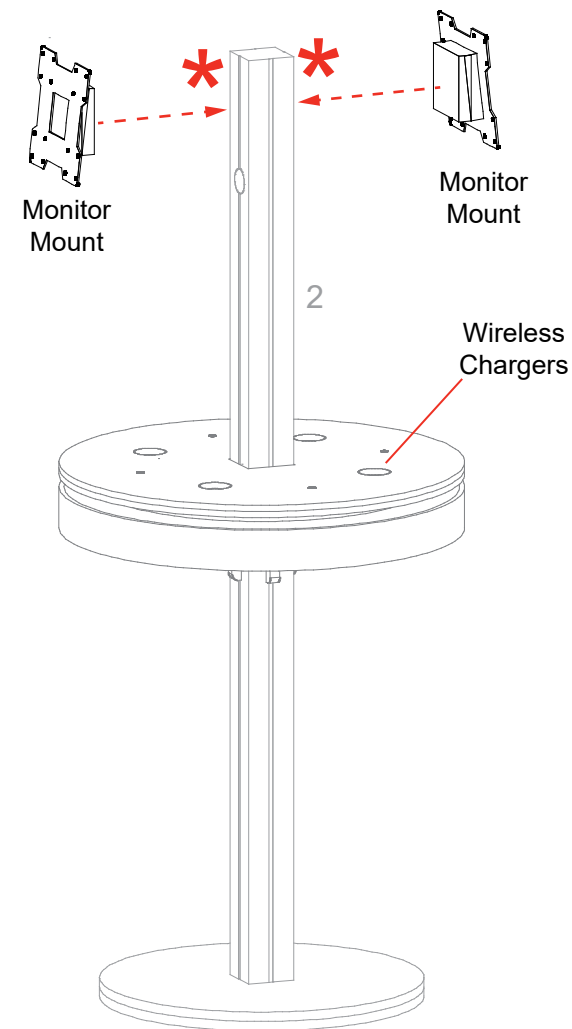
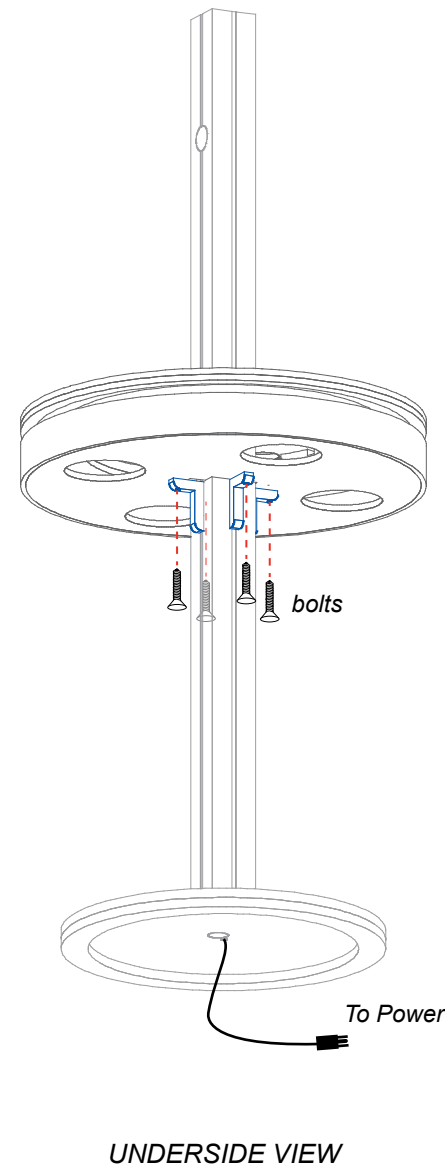
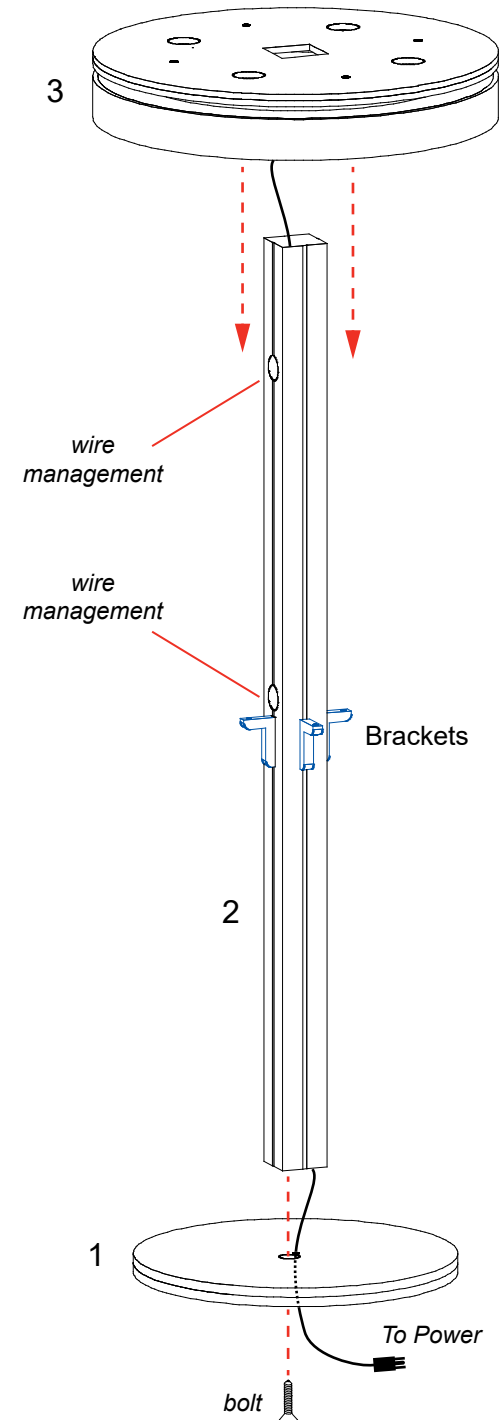

**\* Monitor Mount Attachment**

Slide V4 Connectors into groove of Extrusion. Tighten Set Screws to secure connectors in place.

Attach Monitor Mount back piece to Extrusion, using bolts.

Then slide monitor mount into back piece.

**SETUP INSTRUCTIONS**

## General Setup Instructions

- Read entire setup instruction manual prior to unpacking parts and pieces.
- The setup instructions are created specifically for this configuration.
- Setup instructions are laid out sequentially in steps, including exploded views with detailed explanation for assembly.

## Cleaning & Packing

- For Cleaning Metal, Plex, & Laminate Parts: Use a **MILD NON-ABRASIVE** cleanser and soft cloth/paper towel to clean all surfaces.
- Keep exhibit components away from heat and prolonged sun exposure. **Heat and UV exposure will warp and fade components.**
- Retain all provided Packing Materials. All provided packing materials are for ease of repacking & component protection.

## Disassembly

- For loss prevention, tighten all set screws and locks during disassembly.

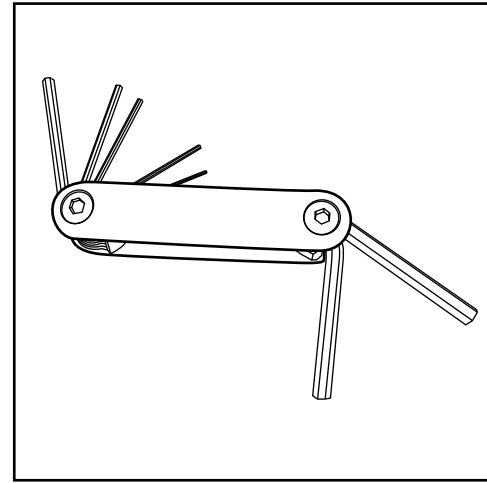

Hex Tool - Essential for Assembly

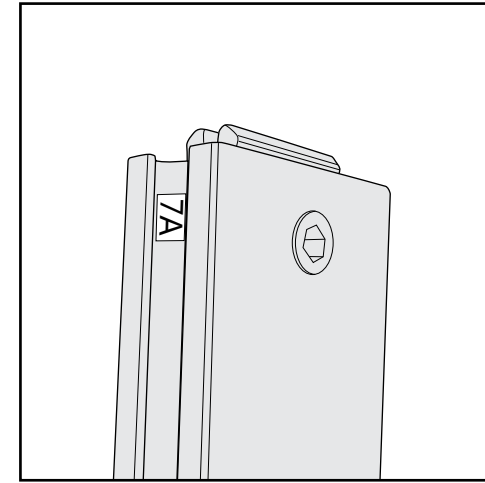

Part Identification - Numbering

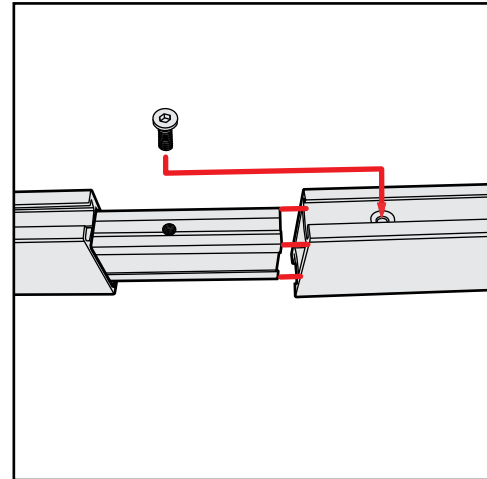

Spline Connection

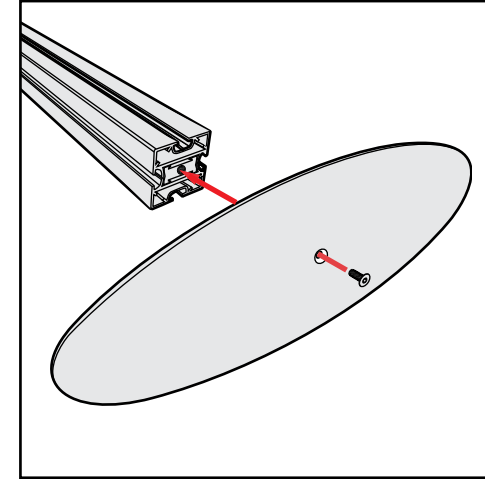

Base Plate & Extrusion Connection

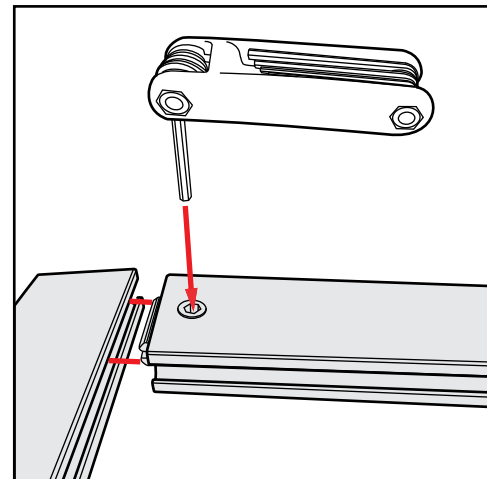

Extrusion & Lock Connection

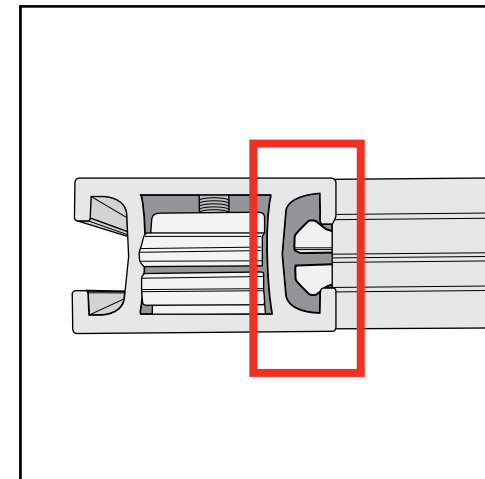

Engaged Lock



**WARNING**



DO NOT USE POWER TOOLS

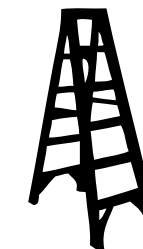

LADDERS OR LIFTS  
MAY BE REQUIRED



ALL CONNECTIONS MUST  
BE TIGHTLY SECURED