

Front View

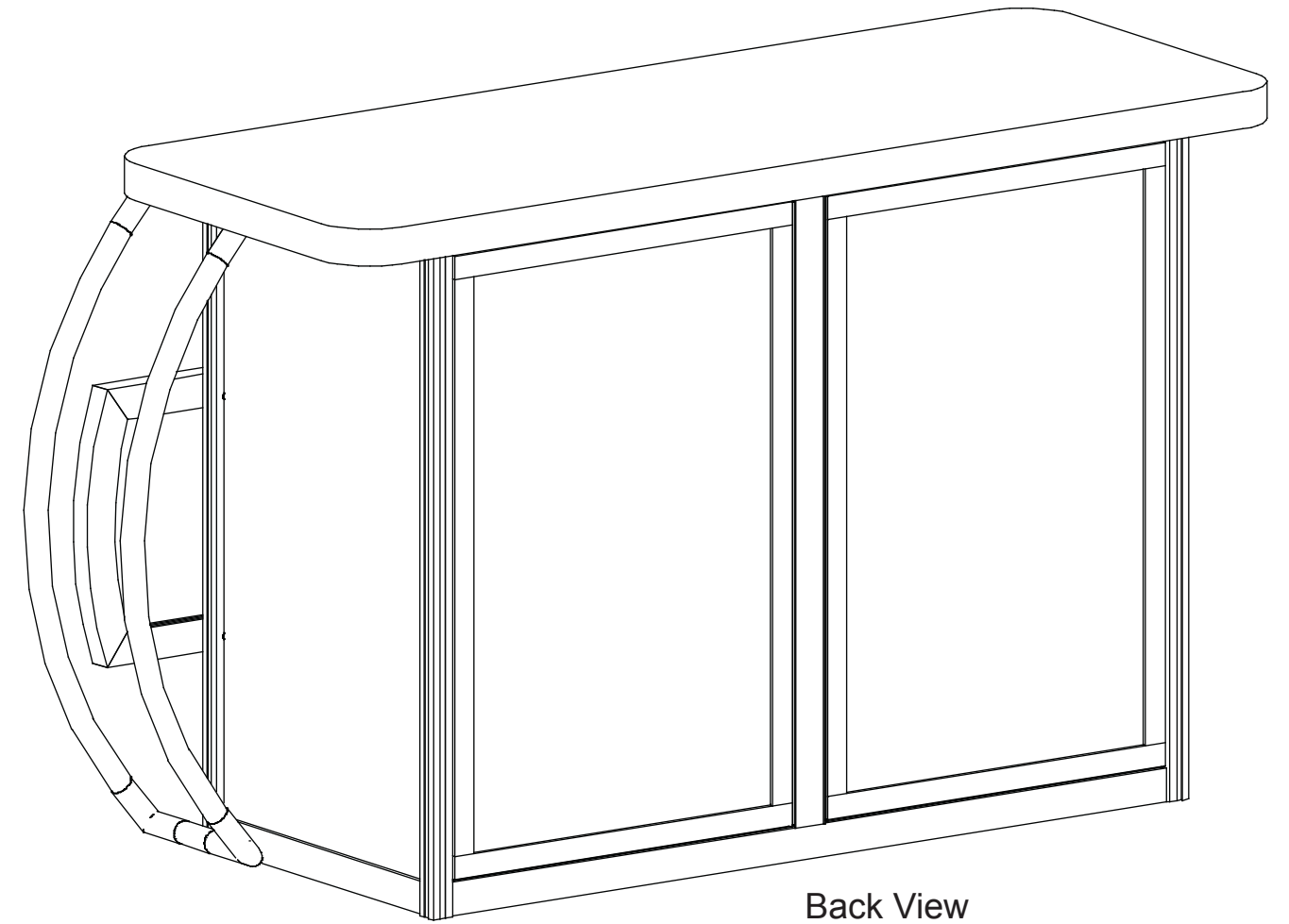

Back View

SETUP INSTRUCTIONS

General Setup Instructions

- Read entire setup instruction manual prior to unpacking parts and pieces.
- The setup instructions are created specifically for this configuration.
- Setup instructions are laid out sequentially in steps, including exploded views with detailed explanation for assembly.

Cleaning & Packing

- For Cleaning Metal, Plex, & Laminate Parts: Use a **MILD NON-ABRASIVE** cleanser and soft cloth/paper towel to clean all surfaces.
- Keep exhibit components away from heat and prolonged sun exposure.
Heat and UV exposure will warp and fade components.
- Retain all provided Packing Materials. All provided packing materials are for ease of repacking & component protection.

Disassembly

- For loss prevention, tighten all set screws and locks during disassembly.

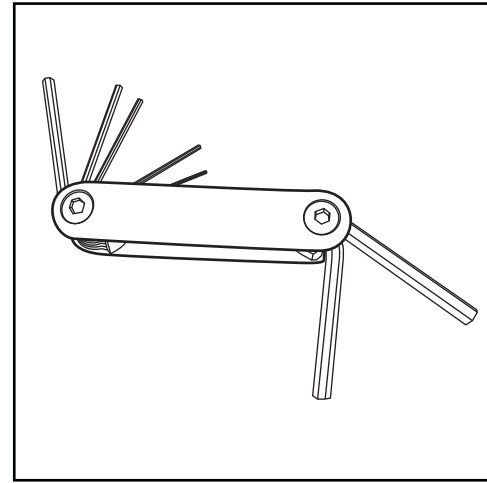

Hex Tool - Essential for Assembly

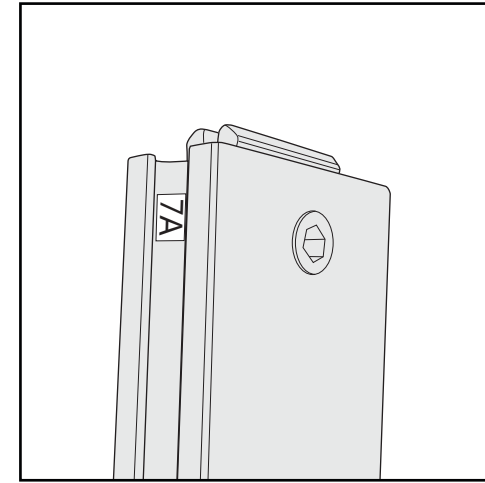

Part Identification - Numbering

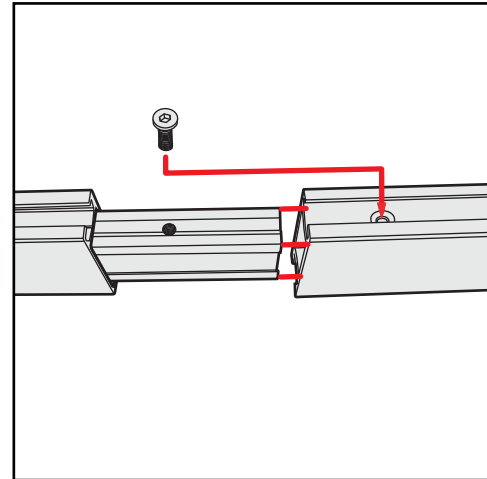

Spline Connection

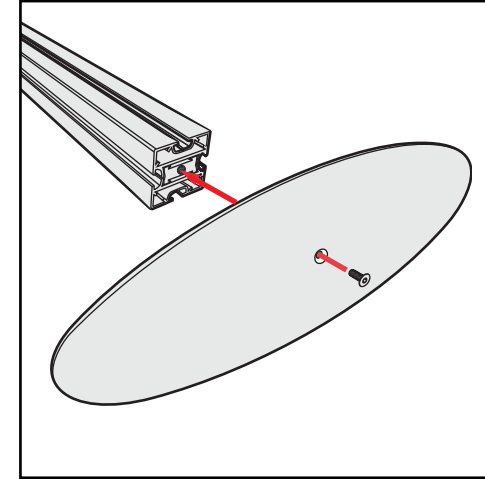

Base Plate & Extrusion Connection

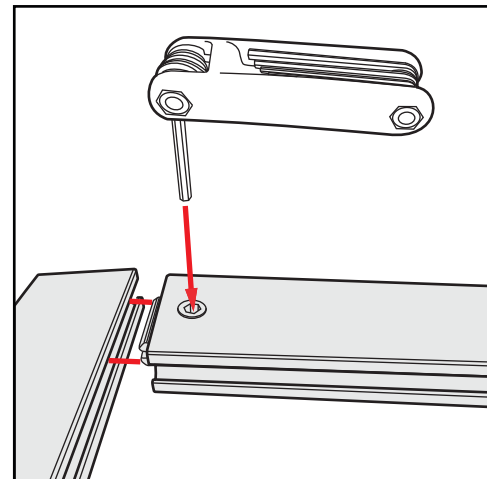

Extrusion & Lock Connection

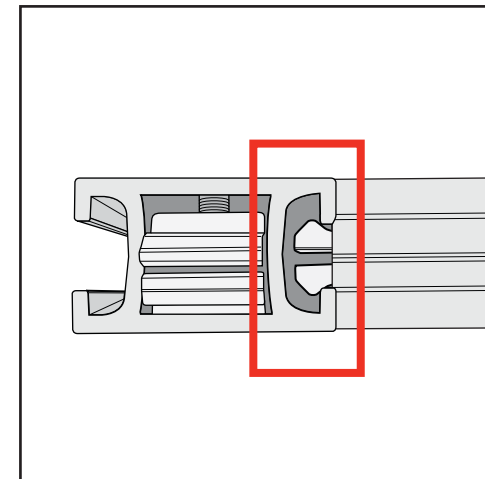

Engaged Lock



WARNING



DO NOT USE POWER TOOLS



LADDERS OR LIFTS
MAY BE REQUIRED



ALL CONNECTIONS MUST
BE TIGHTLY SECURED

SEG Graphic Installation *in 3 Steps*

STEP 1: Attach Corners

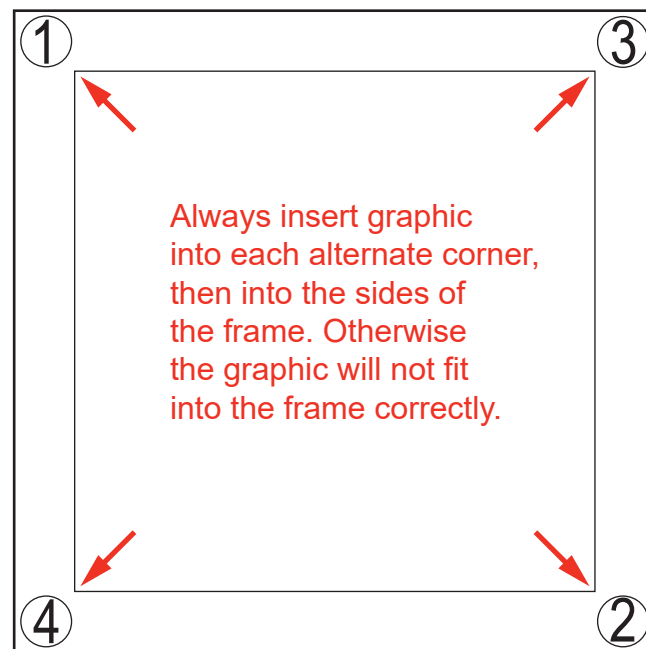

STEP 2: Attach Middle

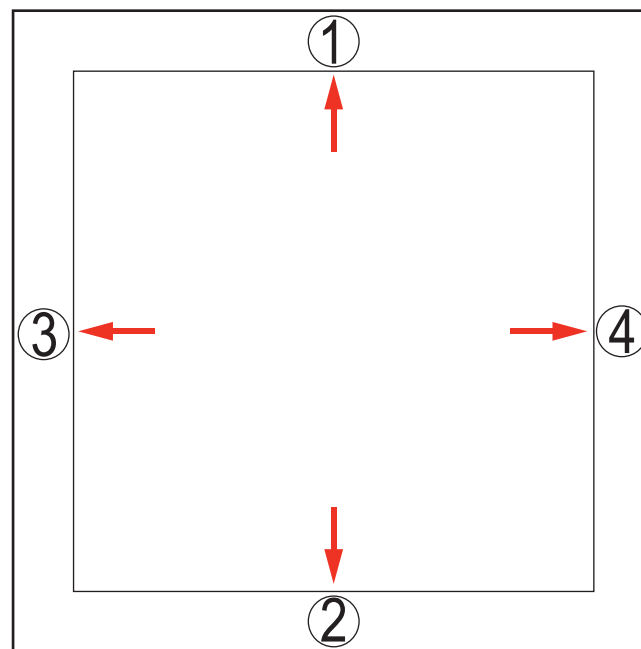

STEP 3: Attach Sides

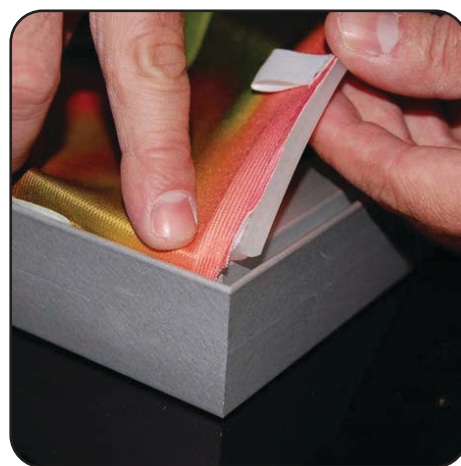
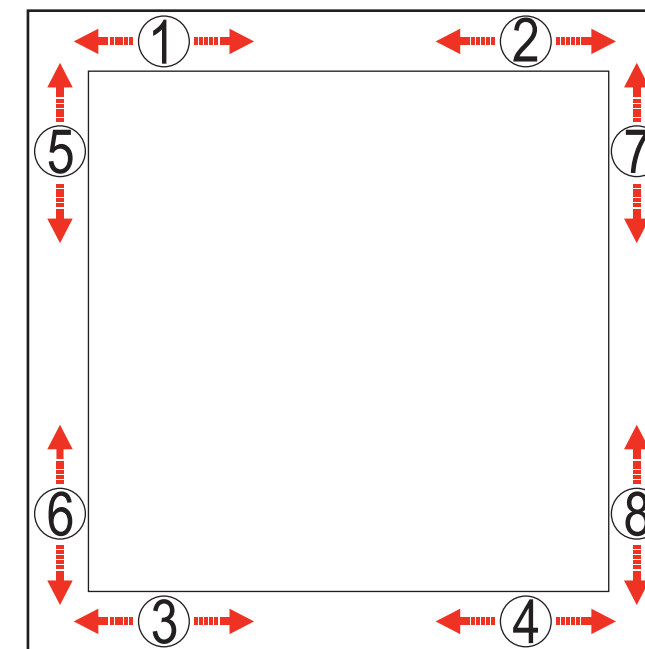

Insert narrow side of silicone welt into the channel at corner 1, with fabric to the outside.

Repeat for opposite corner 2, then corner 3, then corner 4.

Once corners are attached, press the middle of edge 1 into the channel. Then press middle of edge 2 into the channel on opposite side.

Repeat with edge 3 & 4.

Once the middle of sides are attached, fully press the silicone welt into the channel, between center and corner at location 1. Repeat the process between center and corner at location 2.

Do the same for welt on opposite side, at locations 3 & 4. Then repeat for locations 5 & 6 and 7 & 8.

Once the welt is fully inserted on all sides, smooth out edges as needed for a perfect fit.

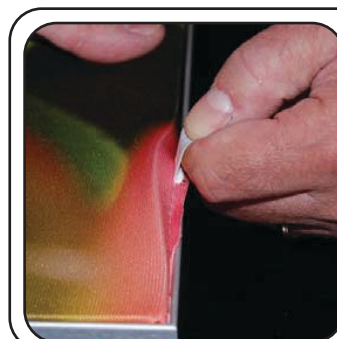

To remove the graphic from the frame, locate the fabric **pull tab**. Gently pull on the tab to remove the graphic.

Install video:



*Retain all packing materials.
DO NOT DISCARD.*



*• Assembly-Disassembly •
If frames or parts are already assembled, do not disassemble.
Retain Assemblies when re-packing.*

Item	Qty.	Description
1	1	37.5" h S44 Vertical Extrusion
2	1	37.5" h S44 Vertical Extrusion
3	1	37.5" h S44 Vertical Extrusion
4	1	37.5" h S44 Vertical Extrusion
5/5A	2/2	18.5" w Z45 Horizontal Extrusion
6/6A/7/7A/7B	1/1/1/1/1	46" w Z45 Horizontal Extrusion
8	1	33.917" h Z45 Vertical Extrusion

Steps:

- 1) Connect lower horizontals [5,6,7] between verticals [1,2,3,4].
- 2) Attach vertical [8] to lower horizontal [6].
- 3) Slide **Infills** between verticals [1,2] and [3,4].
- 4) Slide lower **Infill** between verticals [2] and [3].
- 5) Connect horizontal [7A] between verticals [2,3].
- 6) Slide **Infill** between verticals [2] and [3] and on top of horizontal [7A].
- 7) Connect **Shelf Supports** to Velcro on side Infills, then place Shelf on top of supports.
- 8) Connect Doors to verticals [1] and [4]. See **Door Attachment** detail.
- 9) Connect upper horizontals [5A,6A,7B] between verticals [1,2,3,4] and on top of **Infills** and Doors.

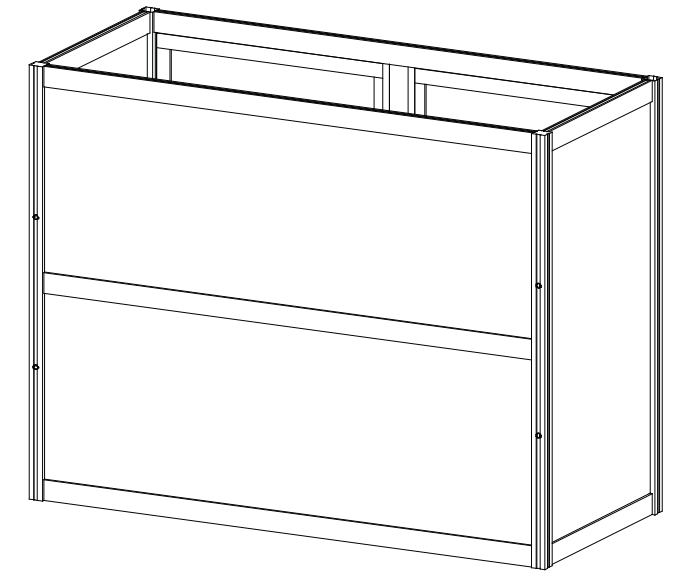
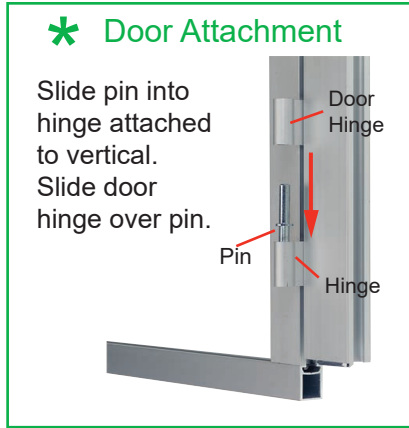

Completed Counter Base Assembly (Front View)

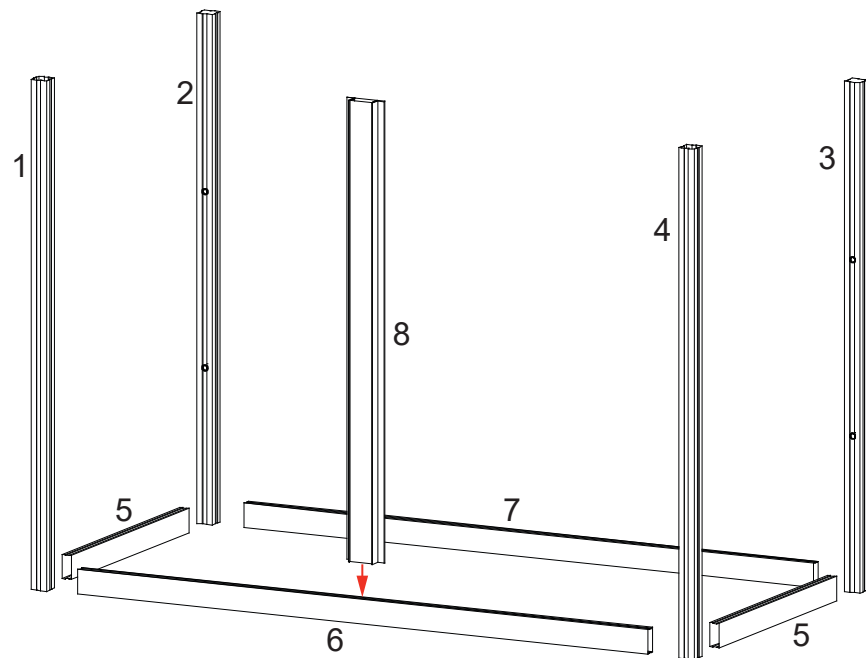

Back View

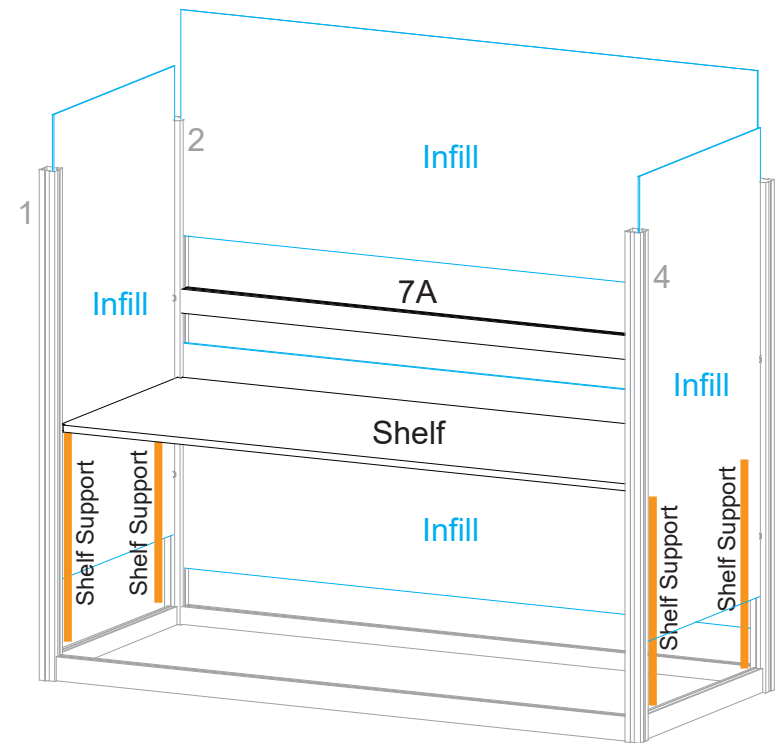

Back View

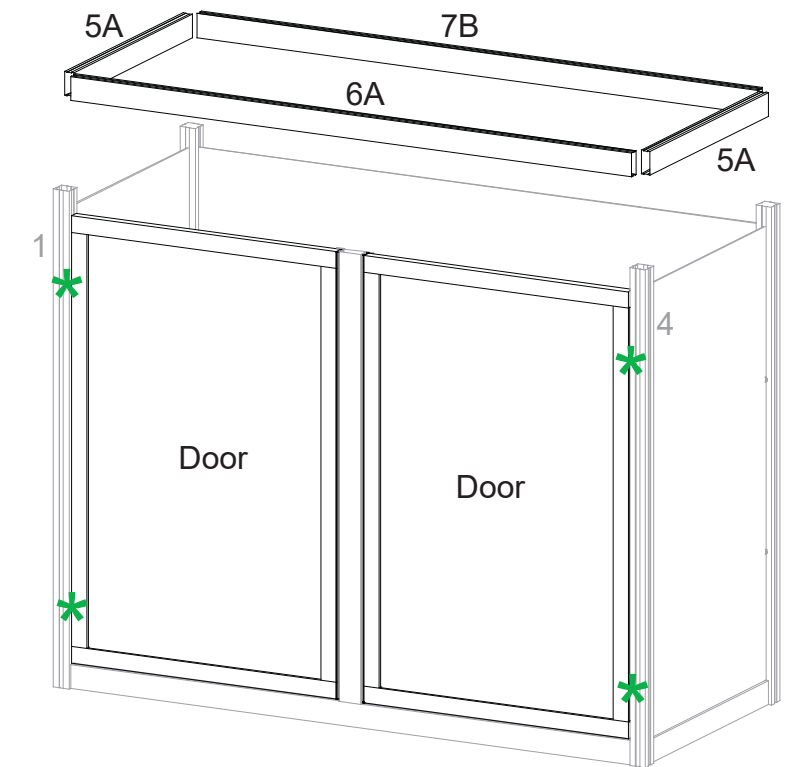

Back View

AERO

Using Your Setup Instructions

The Aero Setup Instructions are created specifically for your configuration. The instructions include an exploded view of the frame which is sequentially labeled. We encourage you to review the instructions before attempting to assemble your exhibit.

Connections are kept very simple; no tools required. Everything assembles with push-button connectors.

Cleaning and Packing Your Display

- 1) Use care when cleaning aluminum extrusion or acrylic inserts. Use only non-abrasive cleaners.
- 2) Retain all packing material. It will make re-packing much easier and will reduce the likelihood of shipping damage.

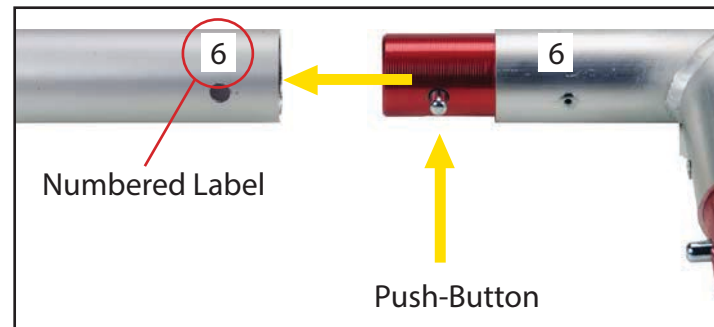

Connections are made by holding the button down and sliding the red tube into opposing tube until button locks into the hole of the opposing tube. To disassemble, push button and pull or twist extrusions apart.

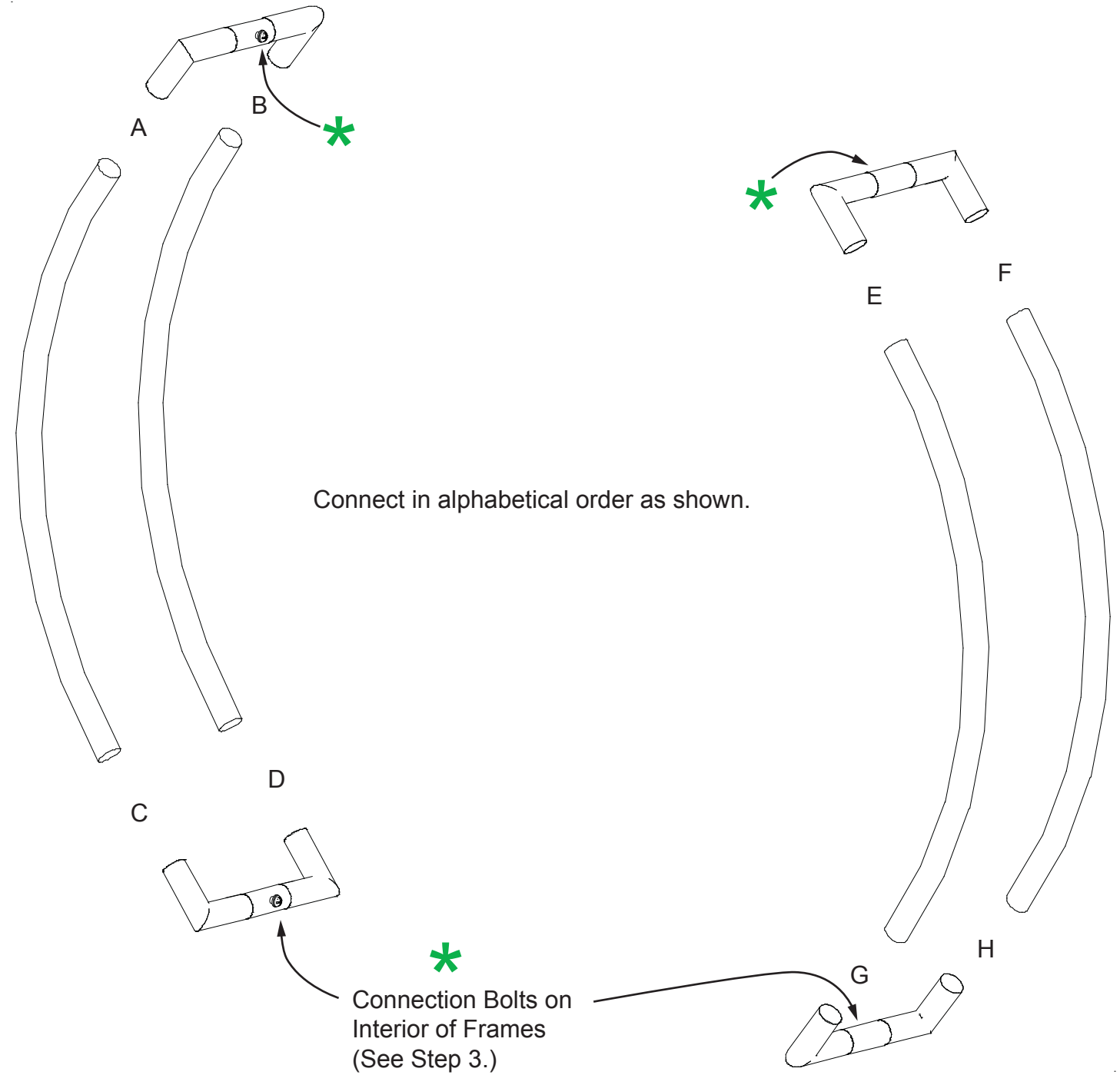
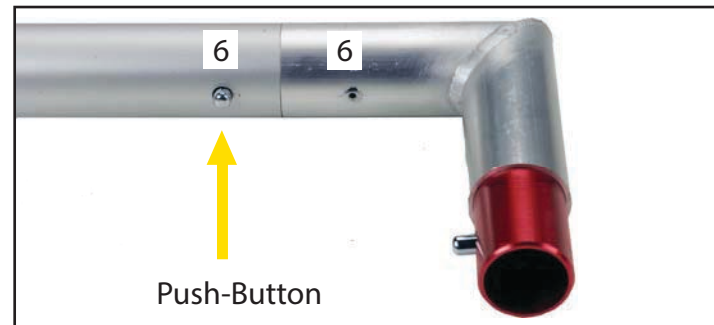

Item	Qty.	Description
9/9A	1/1	15.28" TSP49 Curved Extrusion
10/10A	1/1	30.382"w TSP46 Horizontal Extrusion
11/11A	1/1	30.382"w TSP46 Horizontal Extrusion

- Steps:
- 1) Connect extrusions [9,9A,10,10A,11,11A] together. See [Corner Connection](#) detail.
 - 2) Slide AERO frame assemblies into the side groove of front-most corner verticals [2,3]. See [AERO Attachment](#) detail.
 - 3) Place counter top on top of assembled base. See [Counter Top Attachment](#) detail.
 - 4) Attach SEG frame to verticals [2] & [3], using standoff caps.
 - 5) Attach SEG graphic to SEG frame. See [SEG Graphic Installation, The Perfect Fit](#) page.

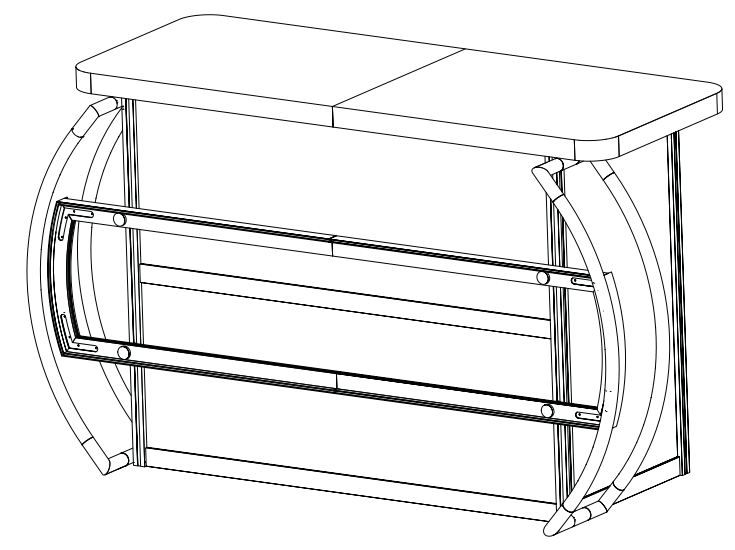

Completed Assembly

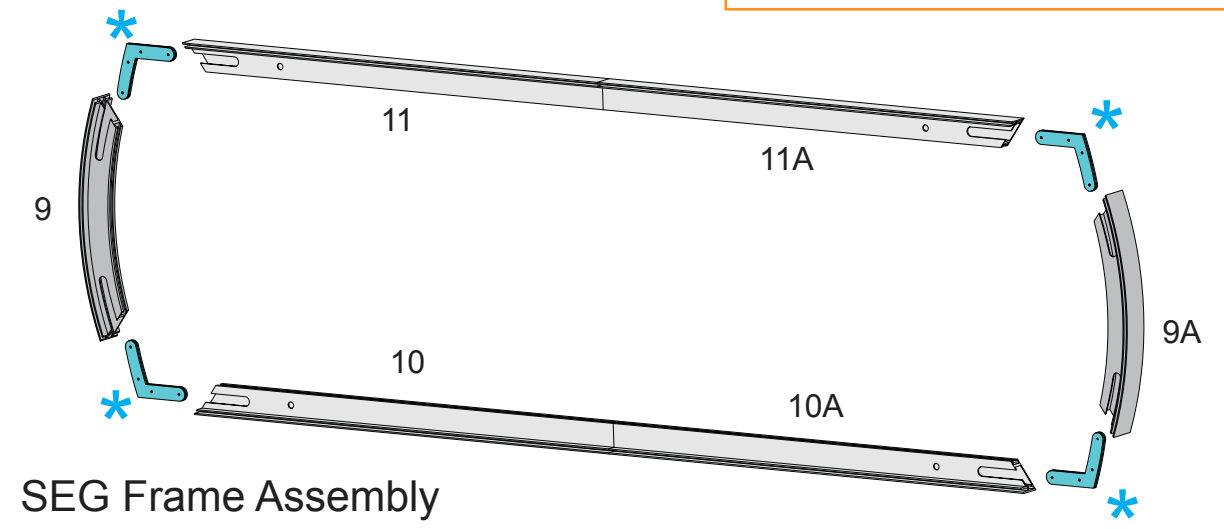
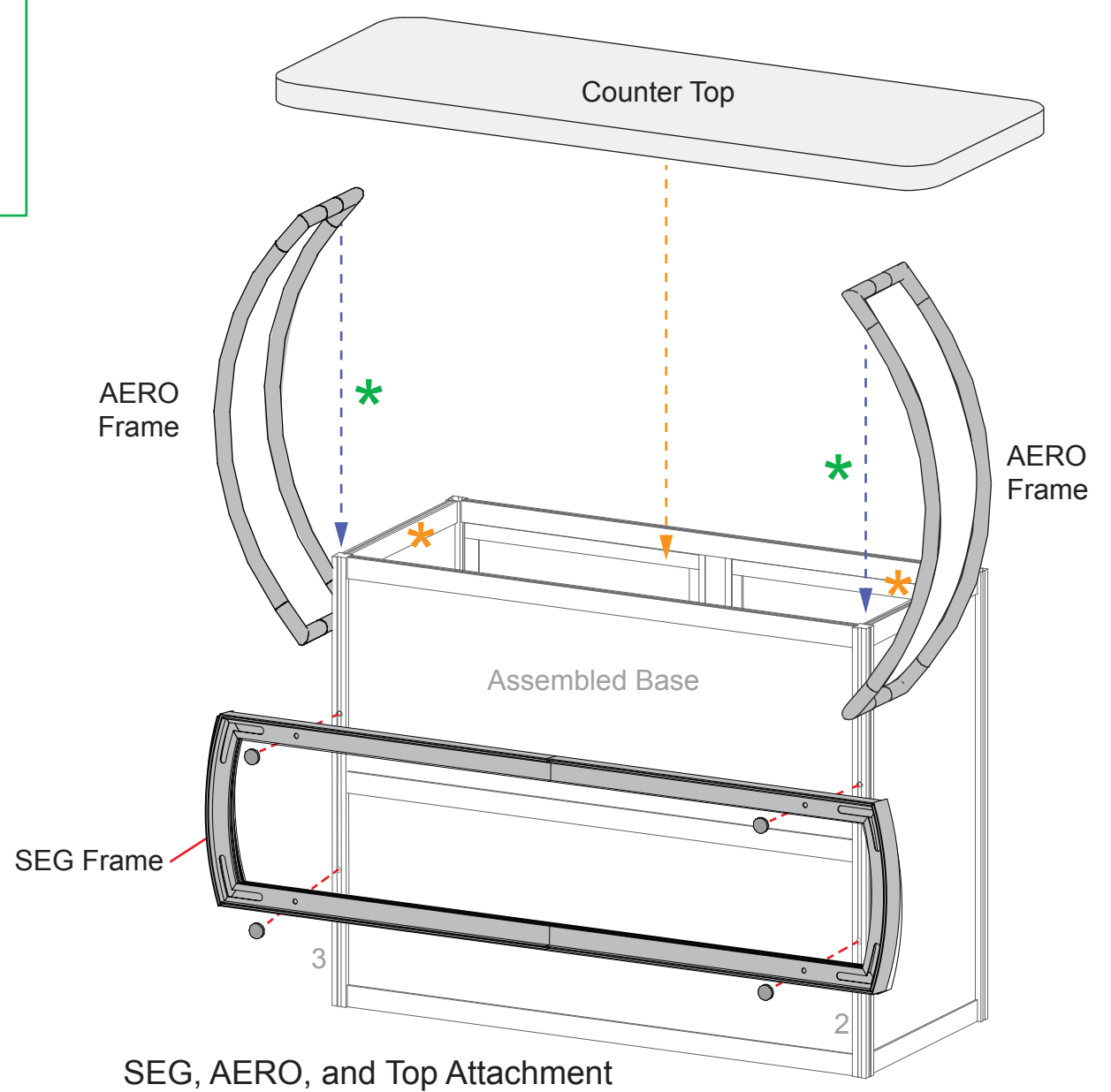
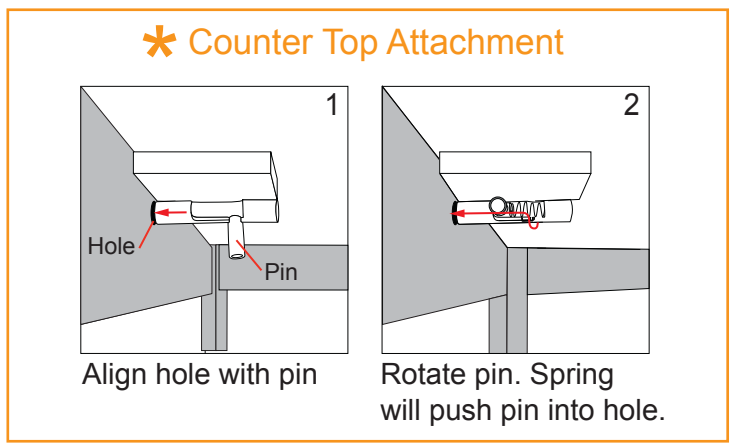
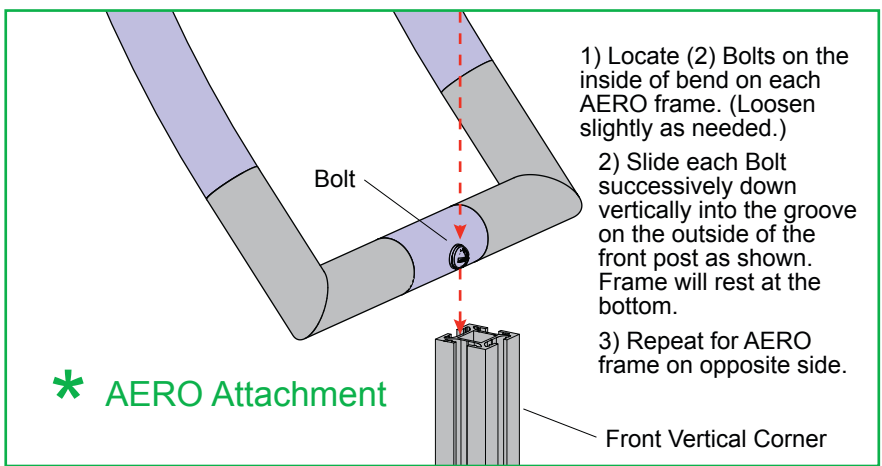
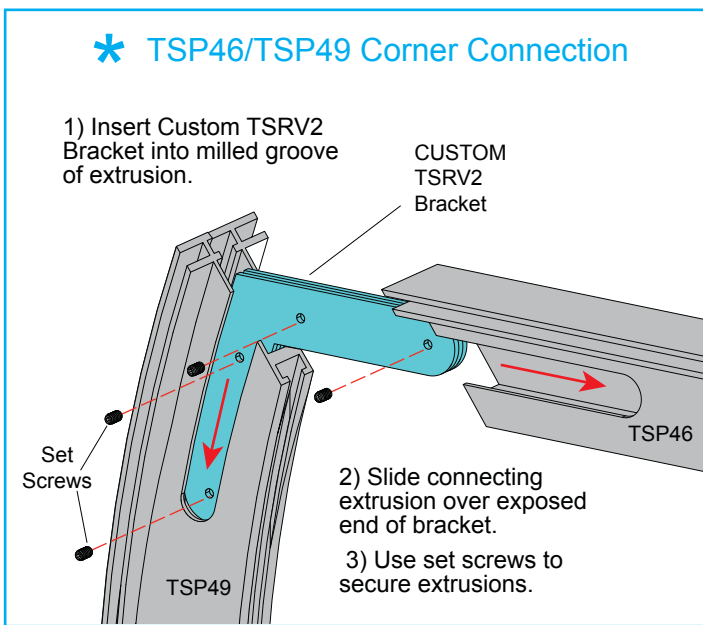

SEG, AERO, and Top Attachment